

028

前脚収納庫扉 Nose Landing Gear Door

■ 接着位置
Cementing position

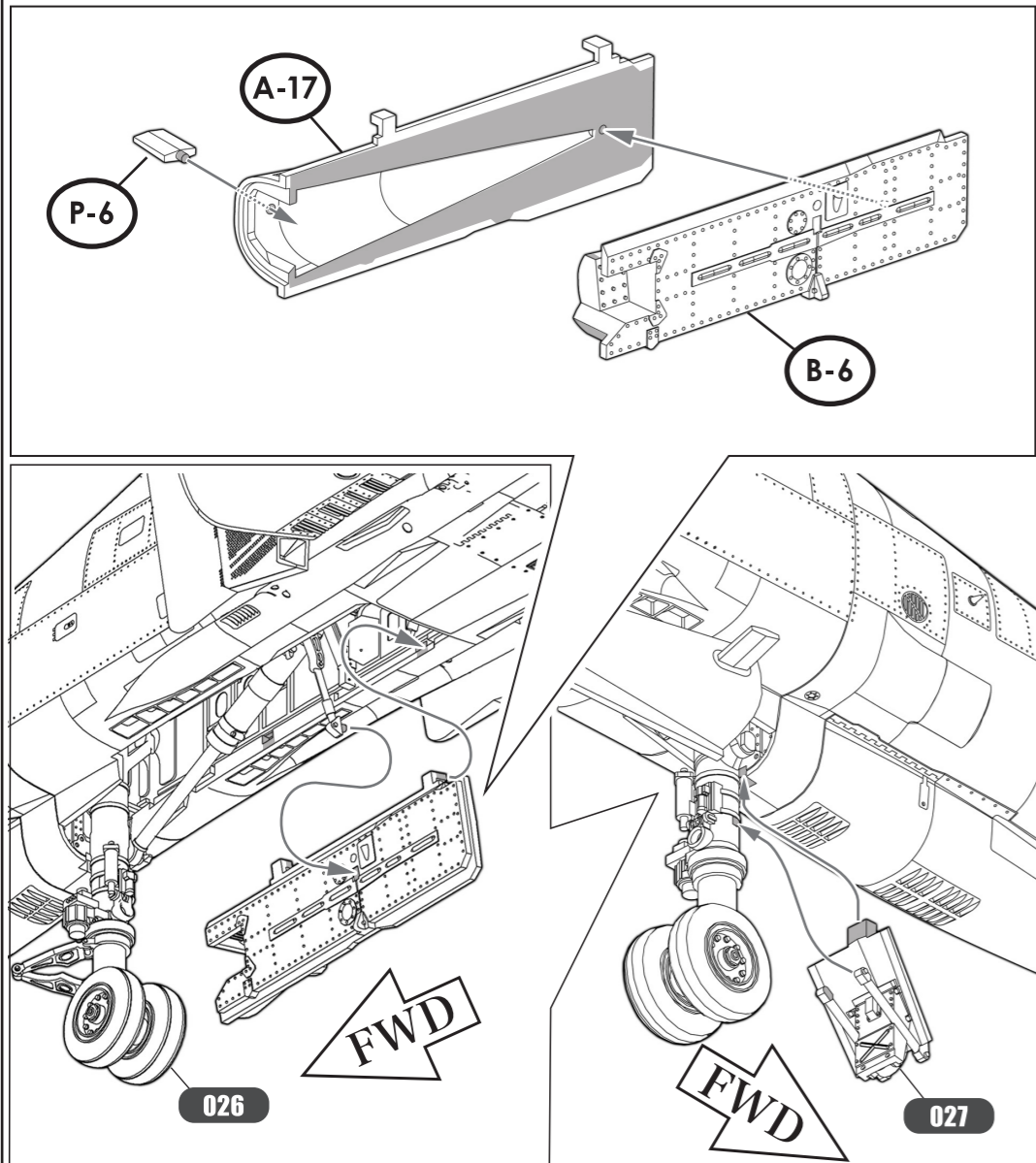

実機におけるパーツ名
Name of the parts of the real aircraft.

- A-17 B-6 前脚収納庫扉 / Nose Landing Gear Door
- P-6 V/UHFアンテナ / V/UHF Antenna

各パーツ接着位置
Parts configuration after assembly.

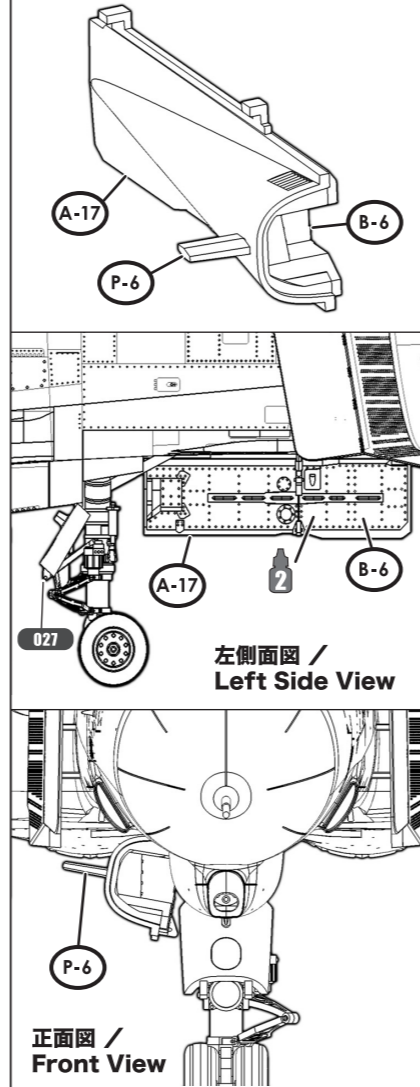

030

主脚 Main Landing Gears

SWS Design Concept

主脚は油圧により内側へ引き込まれます。
The main landing gear was hydraulically retractable into the fuselage.

実機におけるパーツ名
Name of the parts of the real aircraft.

- M-40 主脚扉(右側) / Main Landing Gear Door (Right)
- I-7 主脚アクチュエーター(右側) / Main Landing Gear Actuator (Right)
- M-30 小主脚扉(右側) / Small Main Landing Gear Door (Right)

右翼 / Right Wing

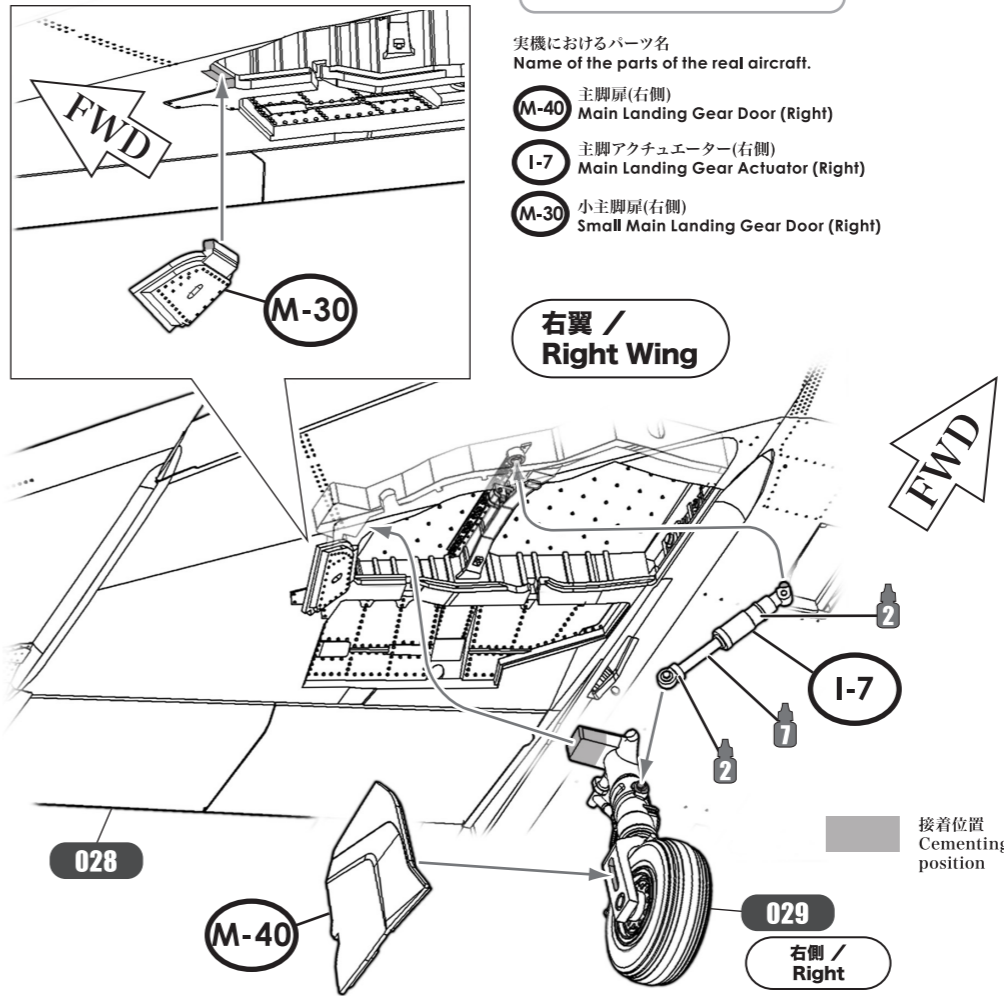

左翼 / Left Wing

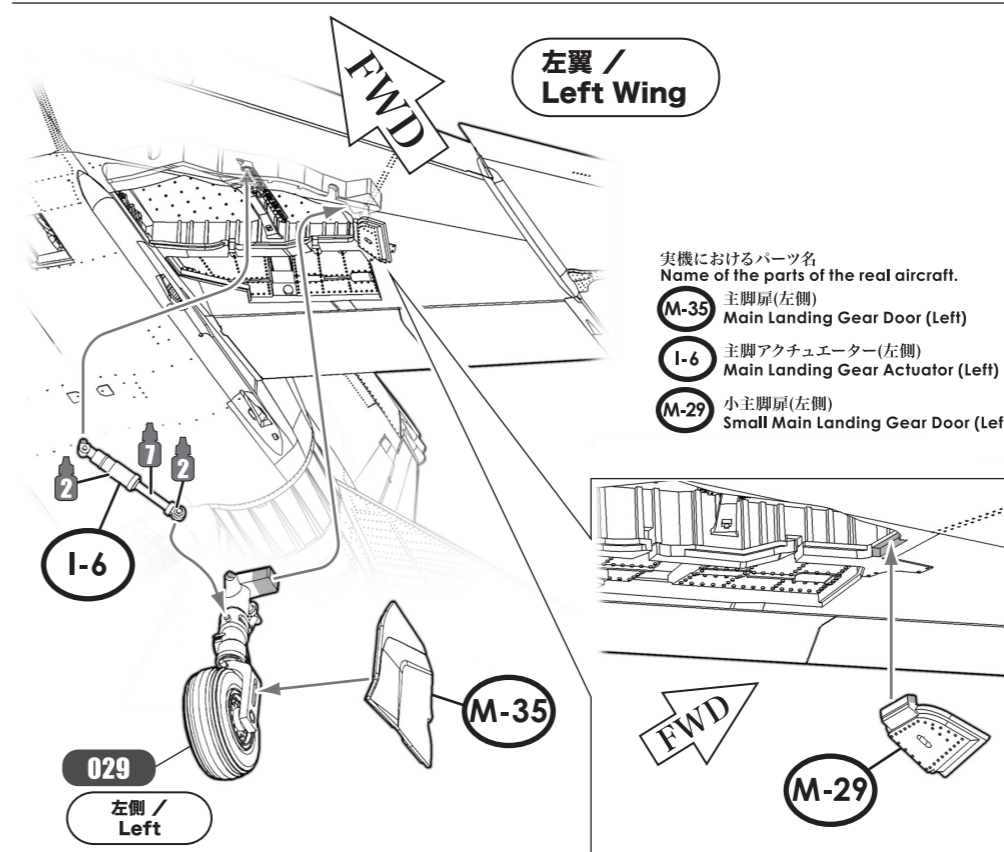

各パーツ接着位置
Parts configuration after assembly.

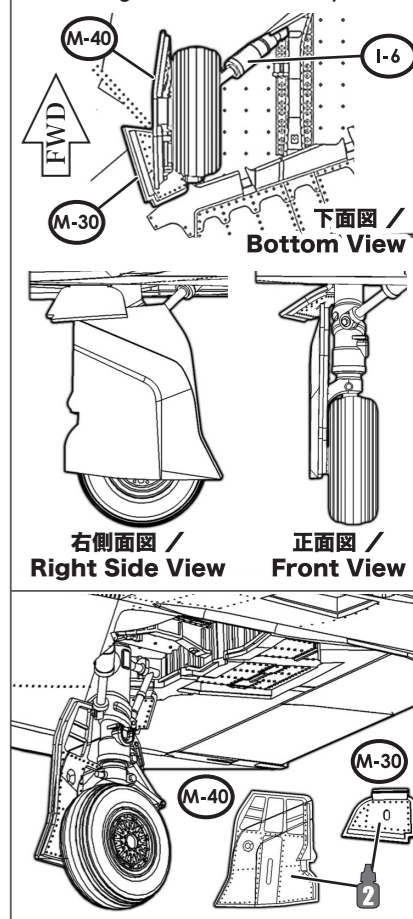

029

主脚支柱とタイヤ Main Landing Gear Struts and Tires

SWS Design Concept

大きなシングルタイヤは、EJ改でも米空軍型と同じ76.2cm×29.2cmという幅の広いタイプで、低圧タイヤ(200psi)です。
The large single tires on the F-4E and F-4EJ Kai had a wide size of 76.2 cm by 29.2 cm, the same type as the USAF F-4 variations, with a low pressure of 200 psi.

■ 接着位置
Cementing position

右側 / Right

左側 / Left

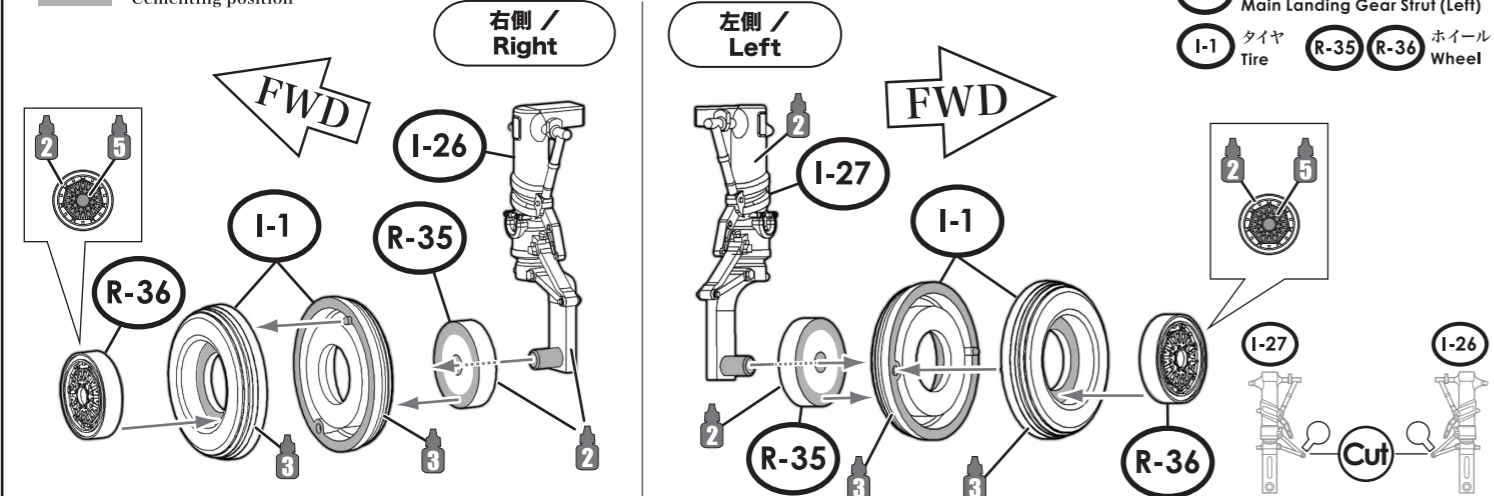

実機におけるパーツ名
Name of the parts of the real aircraft.

- I-26 主脚支柱(右側) / Main Landing Gear Strut (Right)
- I-27 主脚支柱(左側) / Main Landing Gear Strut (Left)
- I-1 タイヤ / Tire
- R-35 R-36 ホイール / Wheel

実機におけるパーツ名
Name of the parts of the real aircraft.

- M-35 主脚扉(左側) / Main Landing Gear Door (Left)
- I-6 主脚アクチュエーター(左側) / Main Landing Gear Actuator (Left)
- M-29 小主脚扉(左側) / Small Main Landing Gear Door (Left)

各パーツ接着位置
Parts configuration after assembly.

