

3-4. B 主脚柱(右側) Main Landing Gear (Right)

実機におけるパーツ名
Name of the parts implemented in the actual aircraft.

N-6 主脚柱(右側)
Main Landing Gear (Right)

N-10 主脚後方支柱(右側)
Main Landing Gear Rear Support (Right)

N-4 N-5 主脚ブラケット
Landing Gear Bracket

N-1 ブレーキパイプ
Brake Pipe

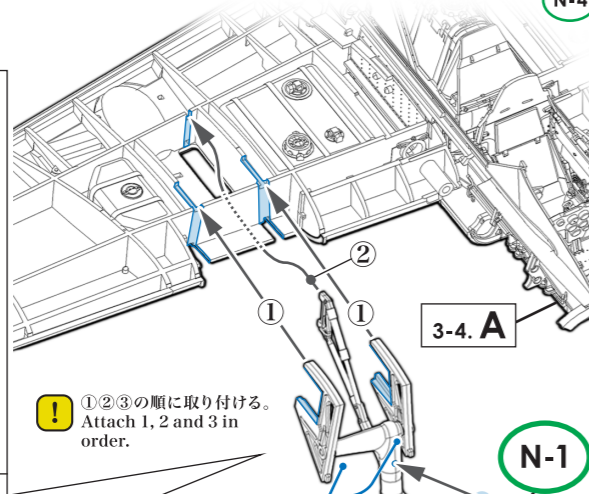
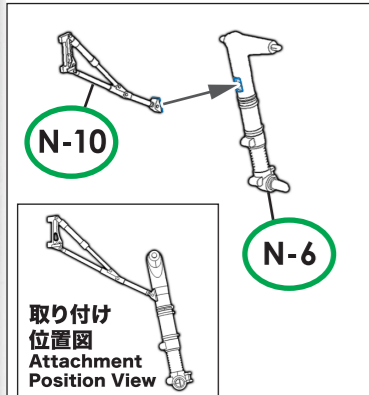

①②③の順に取り付ける。
Attach 1, 2 and 3 in order.

フィニッシャー・アドバイス
Master Advice

流し込みタイプの接着剤
Extra thin cement

接着前の③の部分動かして①②を取り付けた後、③を流し込みタイプの接着剤にて固定します。
Before cementing ③, fit ① and ② into place. Then use an extra-thin liquid cement to attach ③.

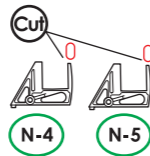

各パーツ接着位置 Parts configuration after assembly.

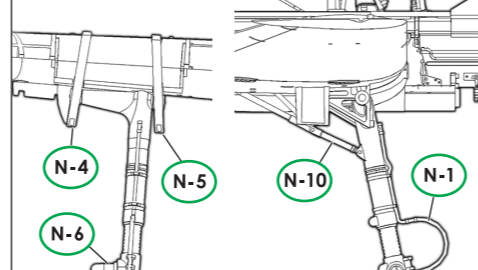

正面図 / Front View

上面図 / Top View

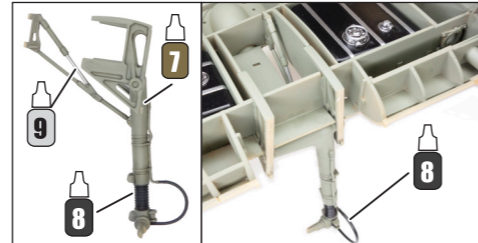

3-4. C 主脚柱(左側) Main Landing Gear (Left)

実機におけるパーツ名
Name of the parts implemented in the actual aircraft.

N-7 主脚柱(左側)
Main Landing Gear (Left)

N-10 主脚後方支柱(左側)
Main Landing Gear Rear Support (Left)

N-2 N-3 主脚ブラケット
Landing Gear Bracket

N-1 ブレーキパイプ
Brake Pipe

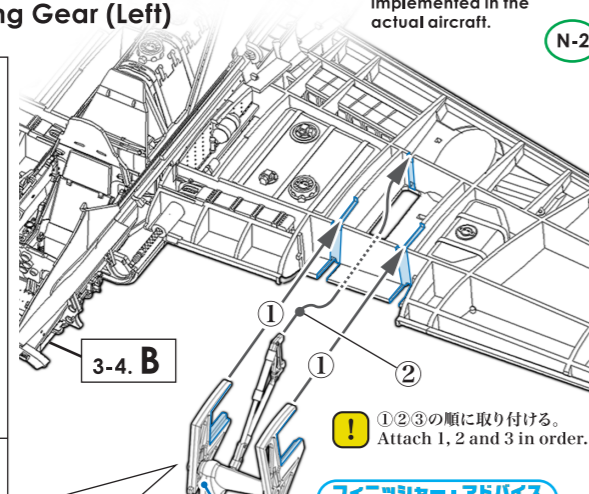
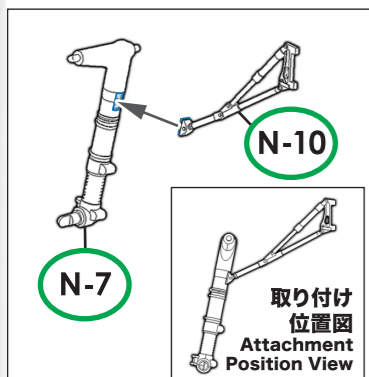

①②③の順に取り付ける。
Attach 1, 2 and 3 in order.

フィニッシャー・アドバイス
Master Advice

流し込みタイプの接着剤
Extra thin cement

接着前の③の部分動かして①②を取り付けた後、③を流し込みタイプの接着剤にて固定します。
Before cementing ③, fit ① and ② into place. Then use an extra-thin liquid cement to attach ③.



各パーツ接着位置 Parts configuration after assembly.

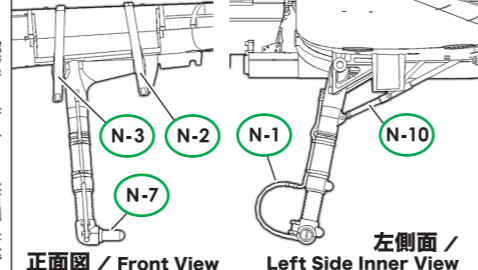

正面図 / Front View

上面図 / Top View



3-4. D 防火壁 Firewall

実機におけるパーツ名
Name of the parts implemented in the actual aircraft.

M-2 M-5 防火壁
Firewall

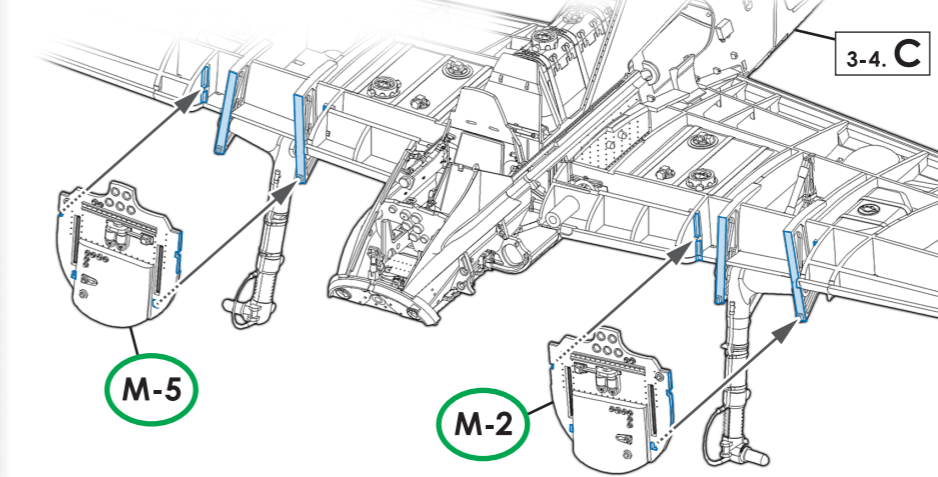

各パーツ接着位置 Parts configuration after assembly.

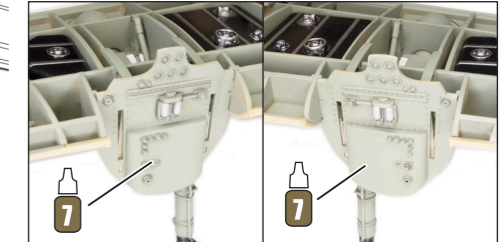
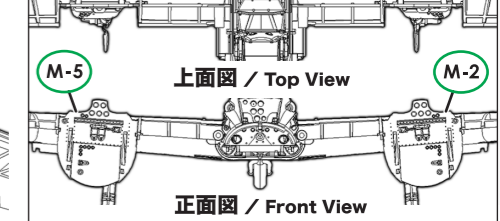

3-4. E 主翼上面外板 Upper Wing Outer Surface Plate

実機におけるパーツ名
Name of the parts implemented in the actual aircraft.

B-2 右内翼上面外板
Right Wing Inboard Top Plate

B-5 右外翼上面外板
Right Wing Outboard Top Plate

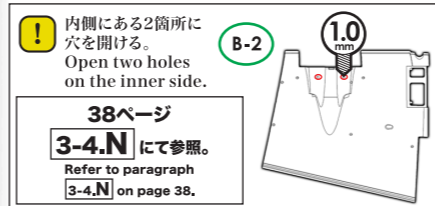

右側 / Right Side

胴体側の外板から取り付ける。
Assemble outward from the fuselage side.

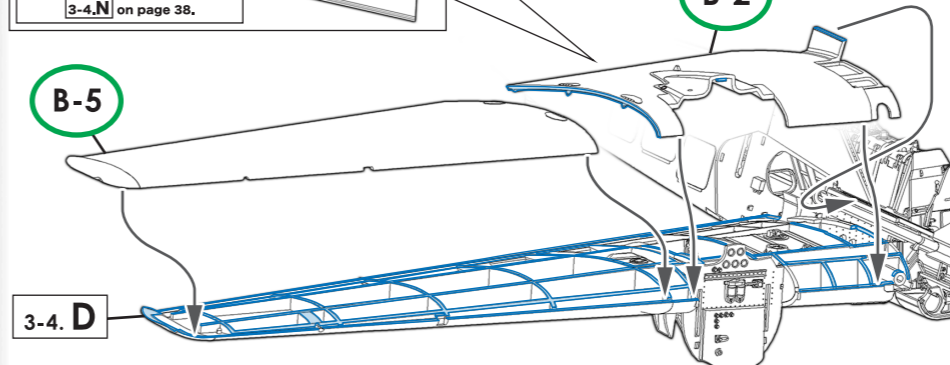

各パーツ接着位置 Parts configuration after assembly.

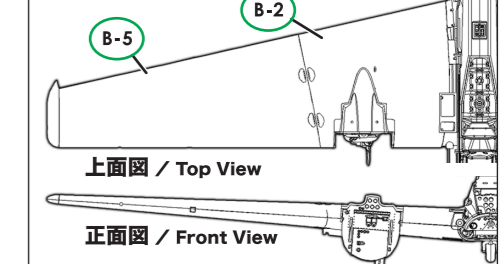

左側 / Left Side

実機におけるパーツ名
Name of the parts implemented in the actual aircraft.

B-3 左内翼上面外板
Left Wing Inboard Top Plate

B-6 左外翼上面外板
Left Wing Outboard Top Plate

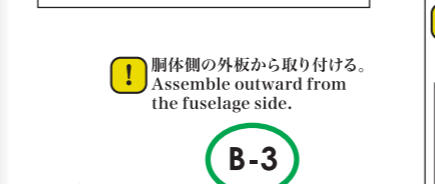

胴体側の外板から取り付ける。
Assemble outward from the fuselage side.

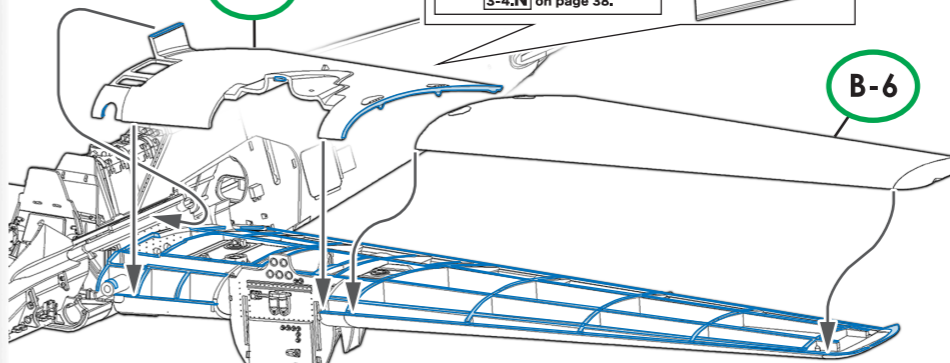

各パーツ接着位置 Parts configuration after assembly.

