

### 3-5. F BK 7,5 装填機 BK 7,5 Ammunition Loader

接着しない / Do Not Cement

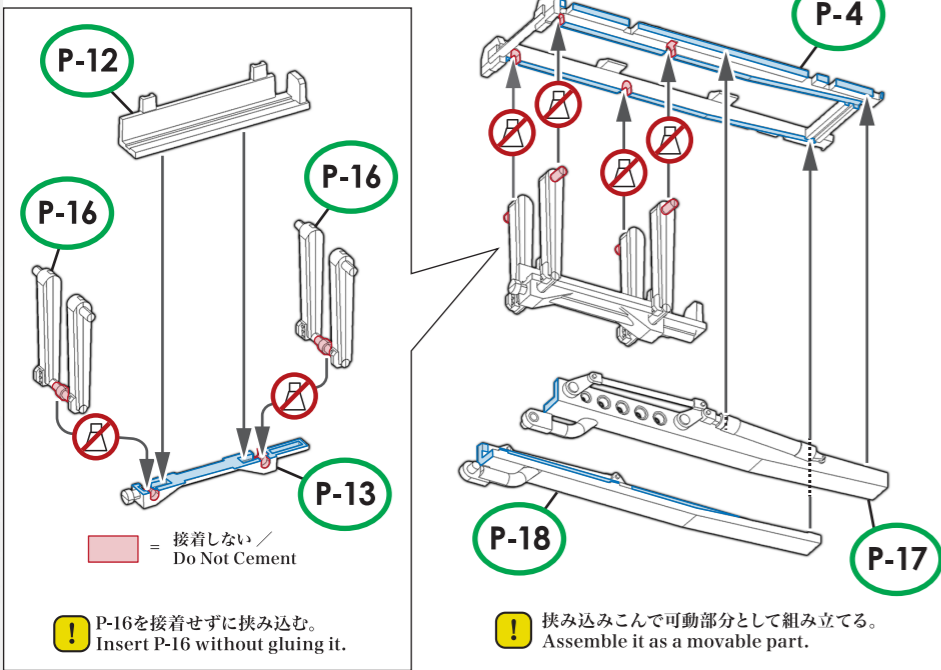

実機におけるパーツ名  
Name of the parts implemented in the actual aircraft.

P-4 P-12 P-13 P-17 P-18 BK 7,5装填機  
BK 7,5 Ammunition Loader

P-16 BK 7,5装填機アーム  
BK 7,5 Ammunition Loader Arms

各パーツ接着位置  
Parts configuration after assembly.

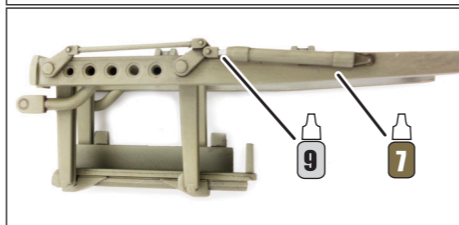
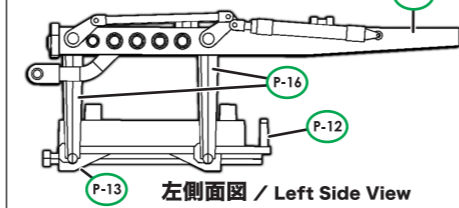

### 3-5. H 自動装填装置 Autoloader

実機におけるパーツ名  
Name of the parts implemented in the actual aircraft.

P-15 P-26 ガスボンベ Gas Bottle P-14 弾倉ドラム輪 Drum Hoops

P-9 支持架支点 Trestle Pivots P-8 弾倉ドラム輪支柱 Drum Hoop Braces

P-7 弾倉ステッパー Drum Stepper

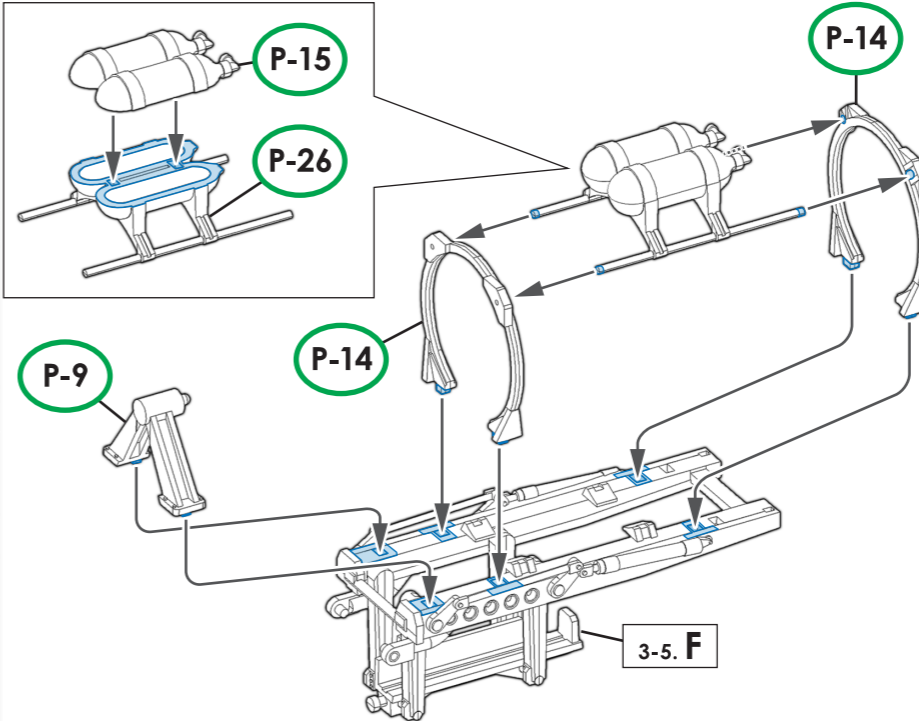

各パーツ接着位置  
Parts configuration after assembly.

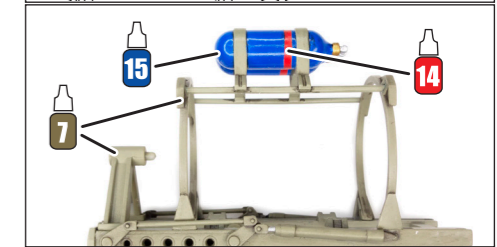
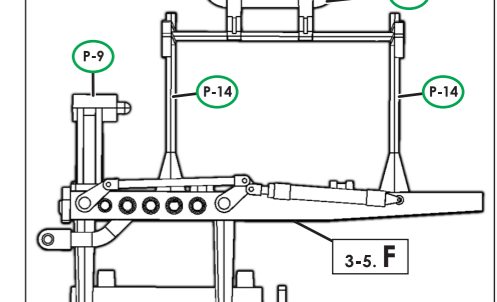

### 3-5. G BK 7,5 弾倉ドラム BK 7,5 Drum Magazine

実機におけるパーツ名  
Name of the parts implemented in the actual aircraft.

P-10 P-11 P-22 BK 7,5 弾倉ドラム  
BK 7,5 Drum Magazine

P-25 75mm 砲弾  
75mm Ammunition

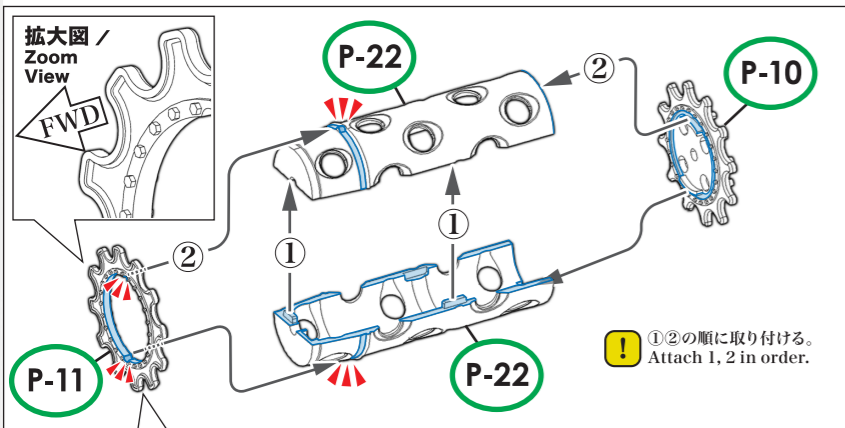

各パーツ接着位置  
Parts configuration after assembly.

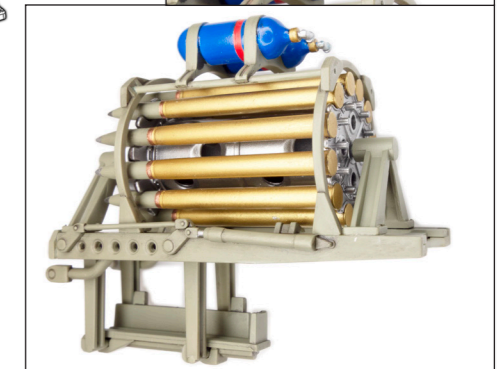
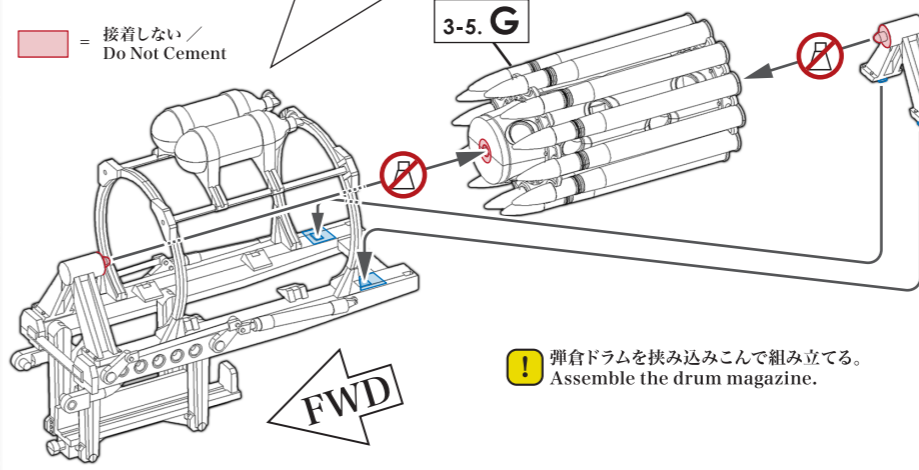
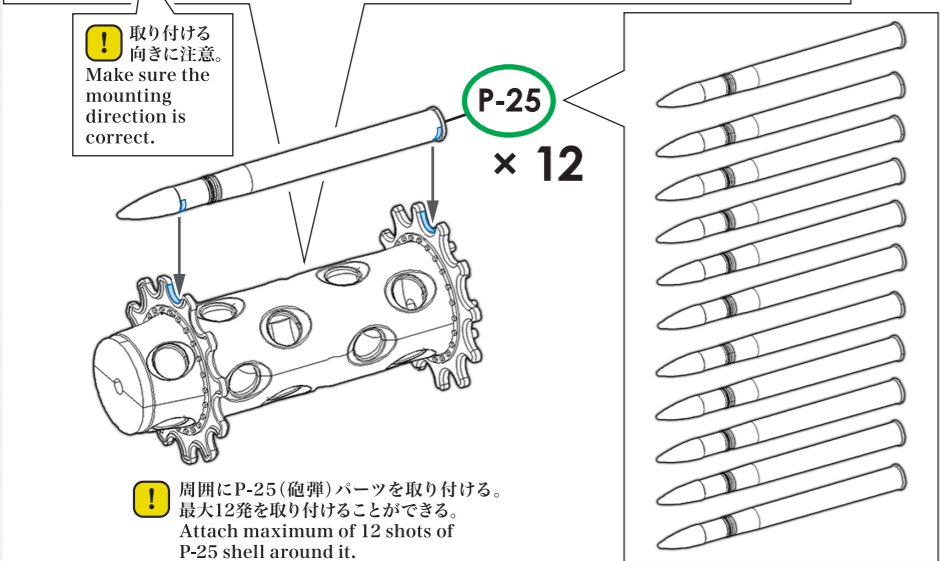
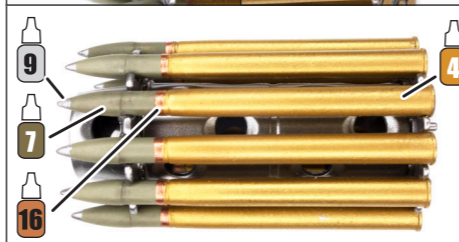
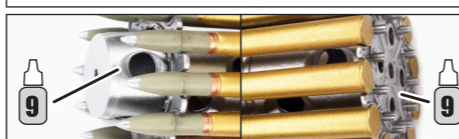
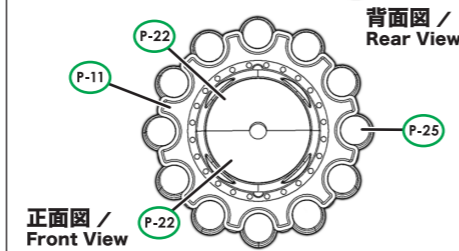
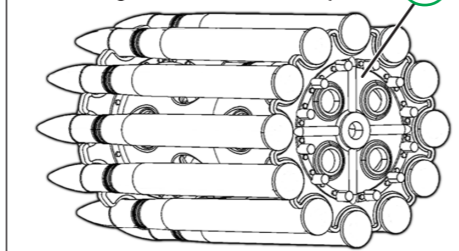

取り付け位置拡大図  
Attachment Position Zoom View

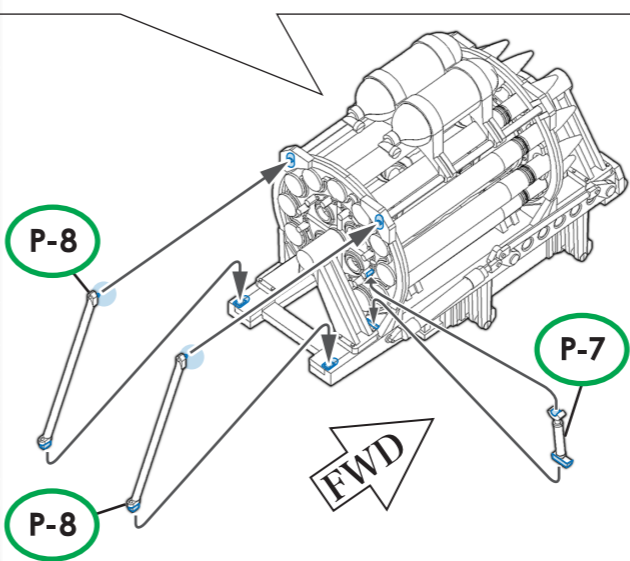

各パーツ接着位置 Parts configuration after assembly.

