

### 3-4. O 尾部と水平尾翼 / Tail and Horizontal Stabilizers

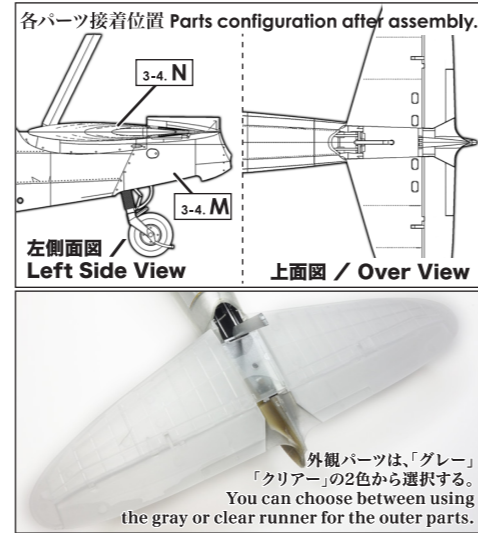

### 3-4. P 垂直尾翼とラダー / Vertical Stabilizer and Rudder

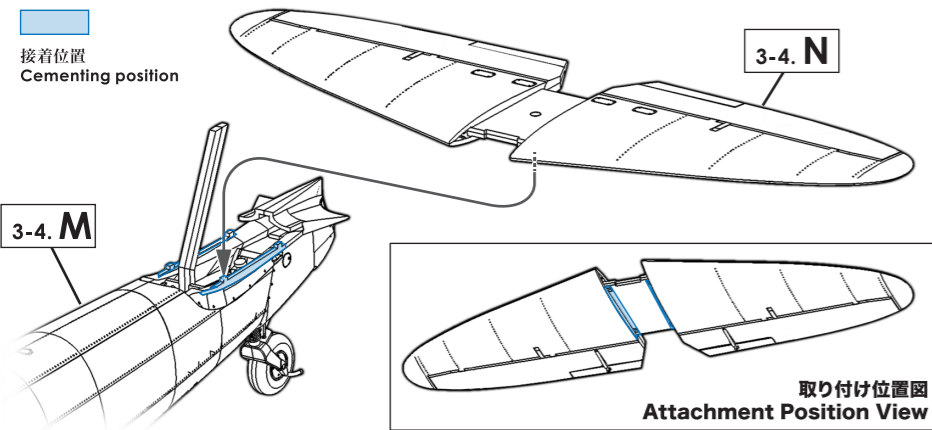
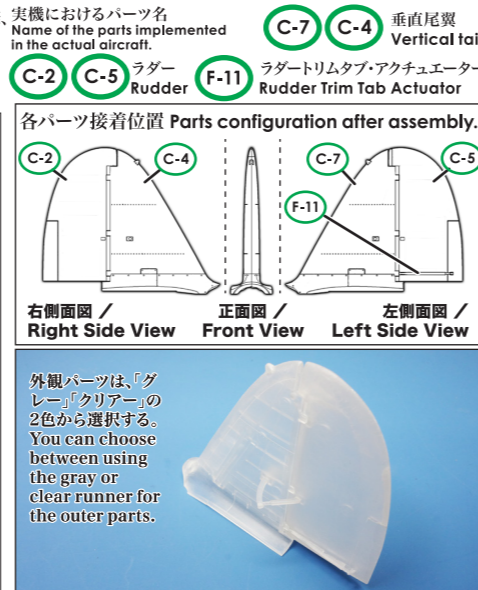
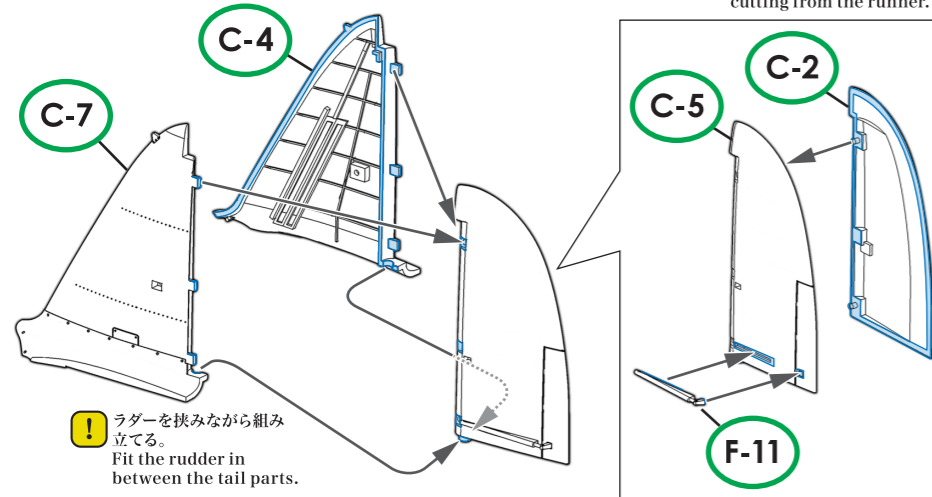

### 3-4. Q 尾部と垂直尾翼 / Tail and Vertical Stabilizer

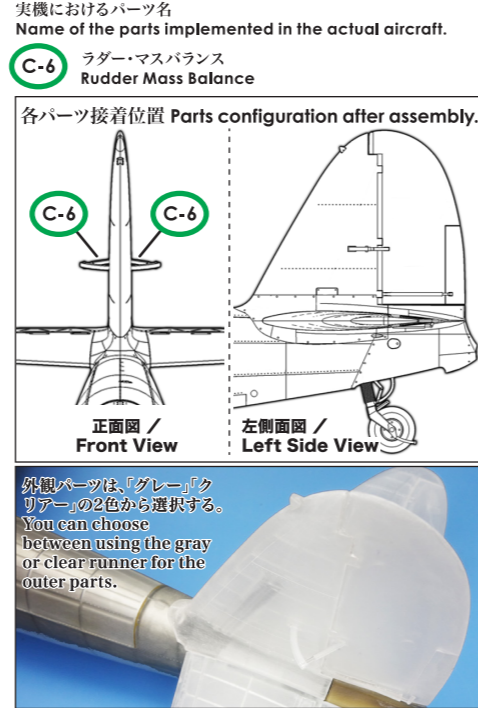
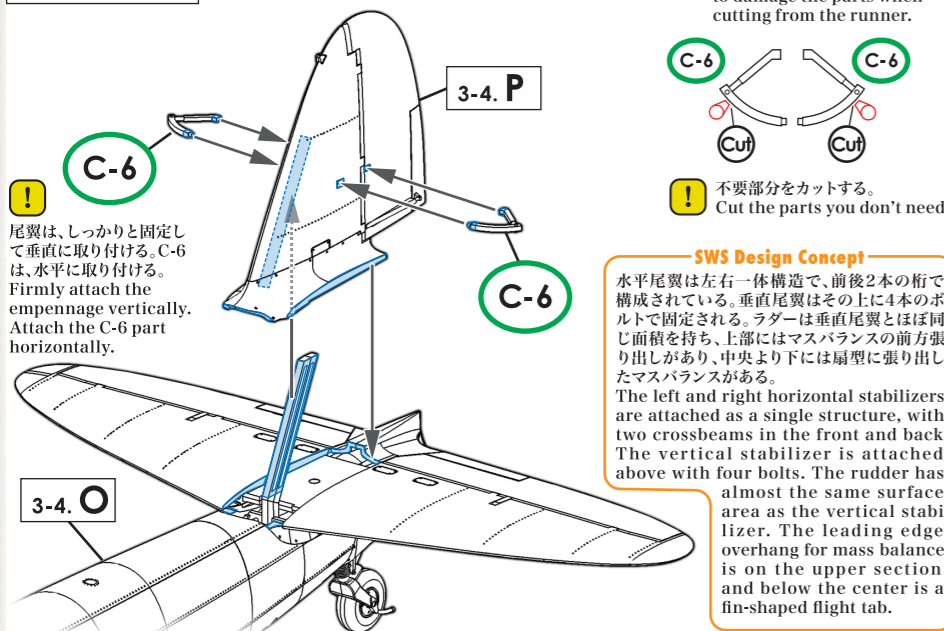

### 3-4. R 主脚タイヤ(右側) / Main Landing Gear Tire (Right)

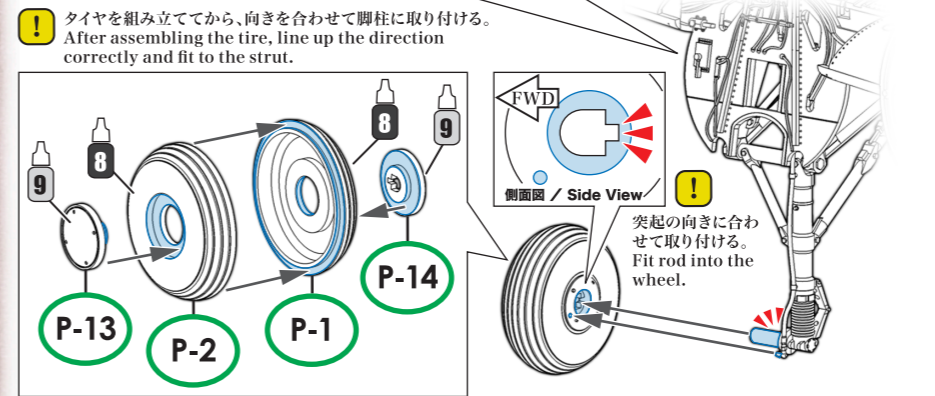
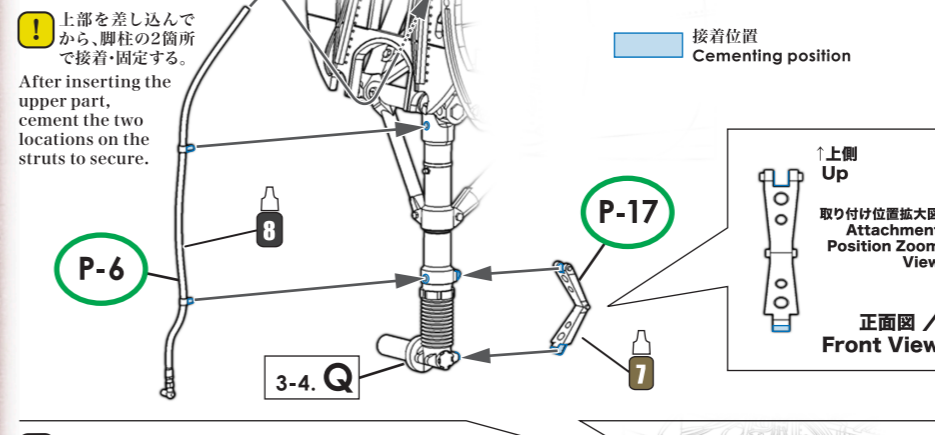

### 3-4. S 主脚タイヤ(左側) / Main Landing Gear Tire (Left)

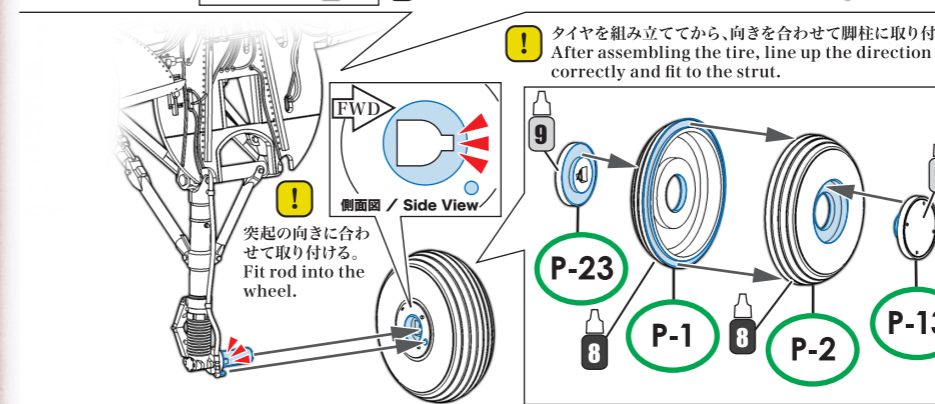
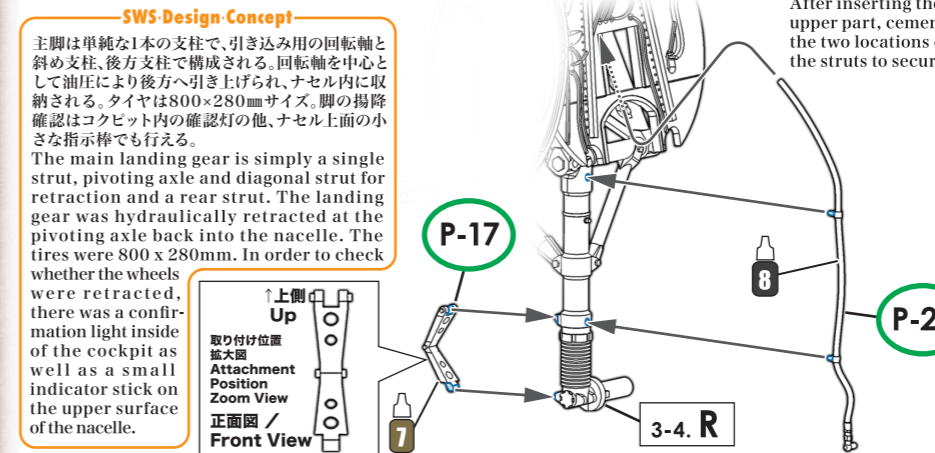

実機におけるパーツ名  
Name of the parts implemented in the actual aircraft.

P-1 P-2 タイヤ / Tire  
P-13 P-14 ホールハブ / Wheel Hub  
P-6 ブレーキパイプ / Brake Pipe  
P-17 トルクアーム / Torque Arm

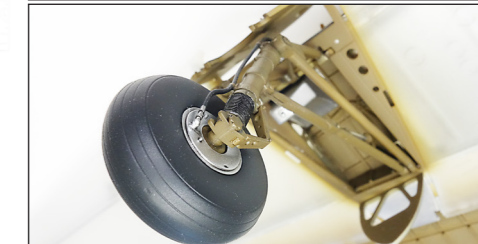
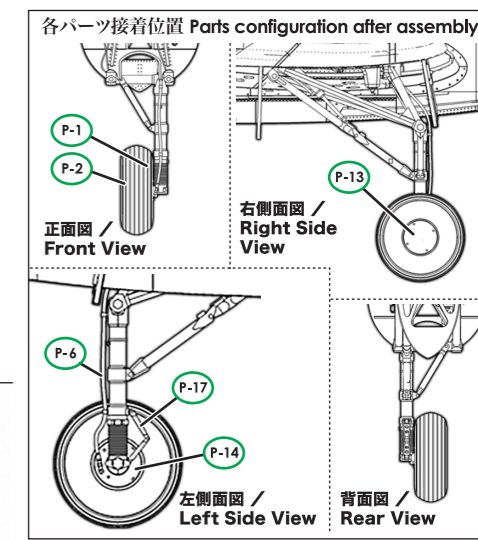

実機におけるパーツ名  
Name of the parts implemented in the actual aircraft.

P-1 P-2 タイヤ / Tire  
P-13 P-23 ホールハブ / Wheel Hub  
P-27 ブレーキパイプ / Brake Pipe  
P-17 トルクアーム / Torque Arm

