

### 3-5. A 機首 Nose

**!** A/B選択(5ページ参照)によって組み立て内容に注意。A選択は武装を組み立てて機首内に装備します。B選択は、武装は付けずに機首のみ取り付けます。  
Note that assembly varies based on your choice of Option A or B (see p.5). For Option A, assemble the armaments and equip to the inside of the fuselage. For Option B, do not attach armaments, and only attach the nose.

### 選択 キ45改丁(後期生産機) Ki-45 Kai Tei (Late Production)

## A Option

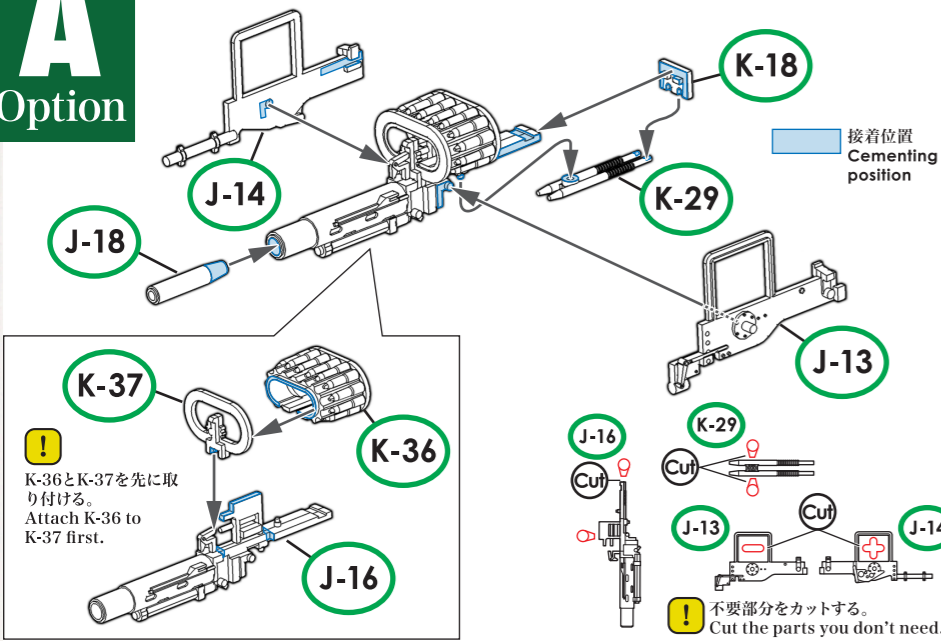

実機におけるパーツ名  
Name of the parts implemented in the actual aircraft.

- J-13 J-14 J-16 J-18 ホ二〇三 三十七耗機関砲 Ho-203 37mm Cannon
- K-18 K-29 K-36 K-37

各パーツ接着位置 Parts configuration after assembly.

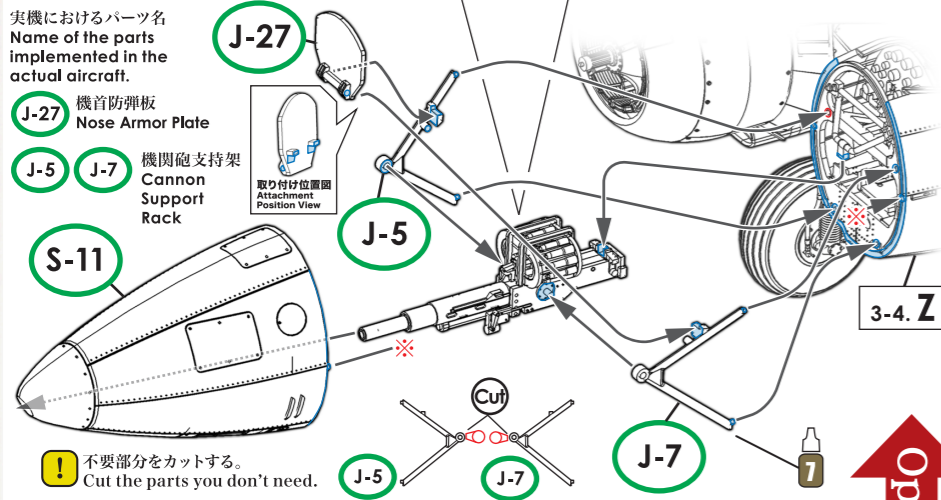
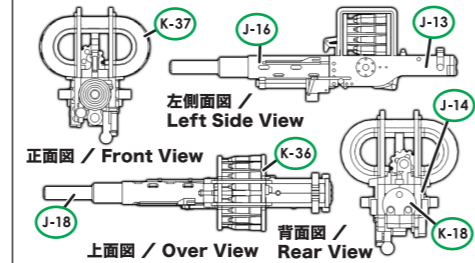

実機におけるパーツ名  
Name of the parts implemented in the actual aircraft.

- J-27 機首防弾板 Nose Armor Plate
- J-5 J-7 機関砲支持架 Cannon Support Rack

各パーツ接着位置 Parts configuration after assembly.

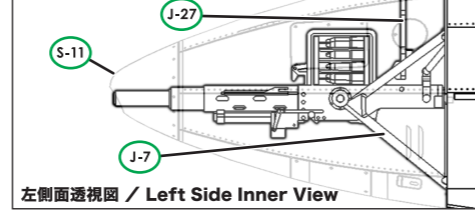

### 選択 キ45改丙、丁(体当たり特別攻撃機) Ki-45 Kai Hei / Tei (Tai-Atari Special Attack Aircraft)

## B Option

#### SWS-Design-Concept

体当たり特別攻撃に使用された機体は、すべての機載武装を外していた。機首のホ二〇三37mm機関砲も外していたが、機首先端の穴はそのままの機体も多かった。  
All armaments were removed from the aircraft to be used for a Tai-Atari special attack. The Ho-203 37mm cannon was also removed, but many aircraft still had the hole for the cannon at the nose.

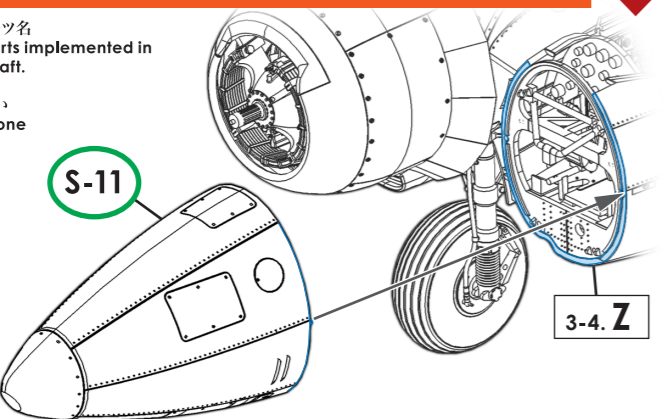

実機におけるパーツ名  
Name of the parts implemented in the actual aircraft.

- S-11 機首覆い Nosecone

各パーツ接着位置 Parts configuration after assembly.

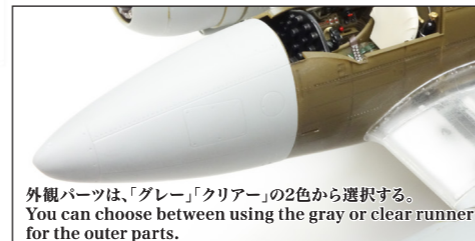
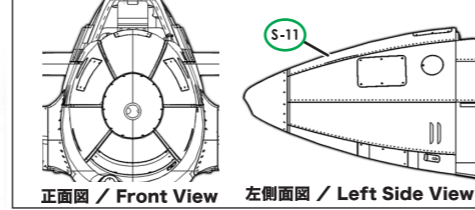

### 3-5. B 照準器 Gun Sight

**!** A/B選択(5ページ参照)によって組み立て内容に注意。A選択は照準器を組み立てて機首内に装備します。B選択は、照準器は付けずに機首のみ取り付けます。  
Note that assembly varies based on your choice of Option A or B (see p.5). For Option A, assemble the gun sight and equip to the inside of the fuselage. For Option B, do not attach the gun sight, and only attach the nose.

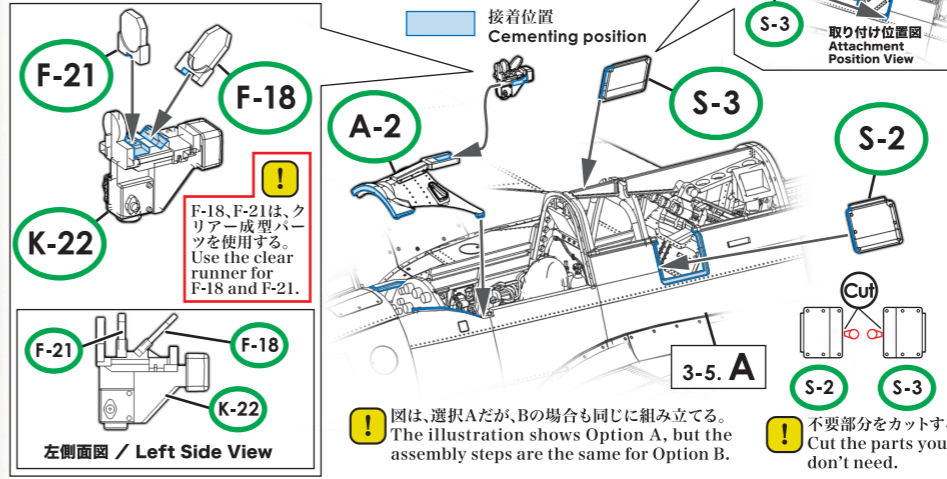

実機におけるパーツ名  
Name of the parts implemented in the actual aircraft.

- F-18 F-21 K-22 照準器 Gun Sight
- A-2 計器盤覆い Instrument Panel Cover
- S-2 S-3 胴体外板 Fuselage Outer Panel

各パーツ接着位置 Parts configuration after assembly.

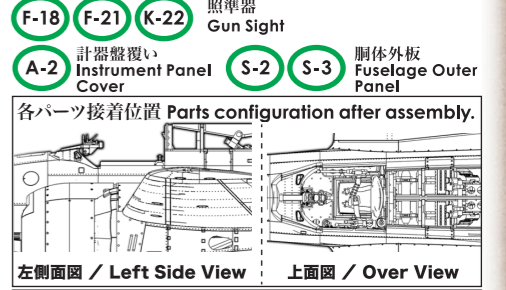

外観パーツは「グレー」「クリアー」の2色から選択する。You can choose between using the gray or clear runner for the outer parts.

### 3-5. C 胴体上部外板 Fuselage Upper Outer Panel

**!** 選択した機体に合わせて組み立てる(5ページ参照)。  
Assemble the model according to the version of your choice (see p.5)

### 選択 キ45改丁(後期生産機) Ki-45 Kai Tei (Late Production)

## A Option

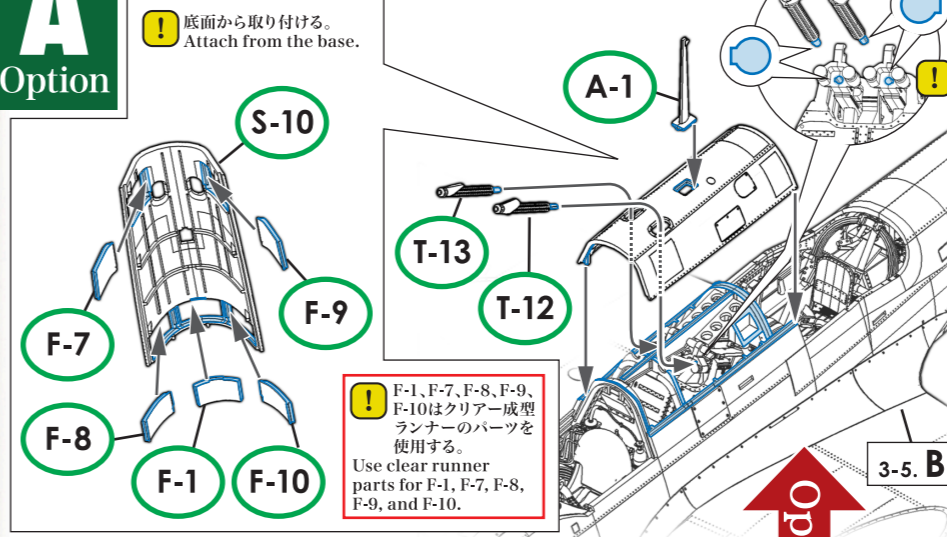

実機におけるパーツ名  
Name of the parts implemented in the actual aircraft.

- F-1 F-7 F-8 窓ガラス Window Pane
- F-9 F-10
- S-10 胴体上部外板 Fuselage Upper Outer Panel
- A-1 アンテナ支柱 Antenna Mast

各パーツ接着位置 Parts configuration after assembly.

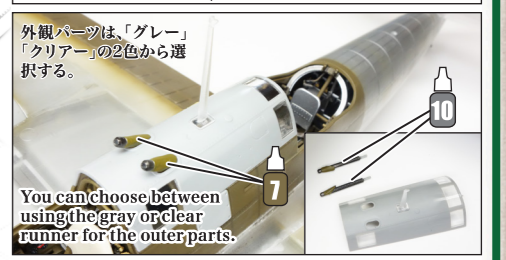
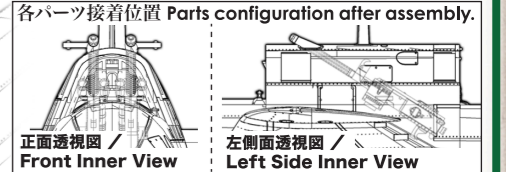

### 選択 キ45改丙、丁(体当たり特別攻撃機) Ki-45 Kai Hei / Tei (Tai-Atari Special Attack Aircraft)

## B Option

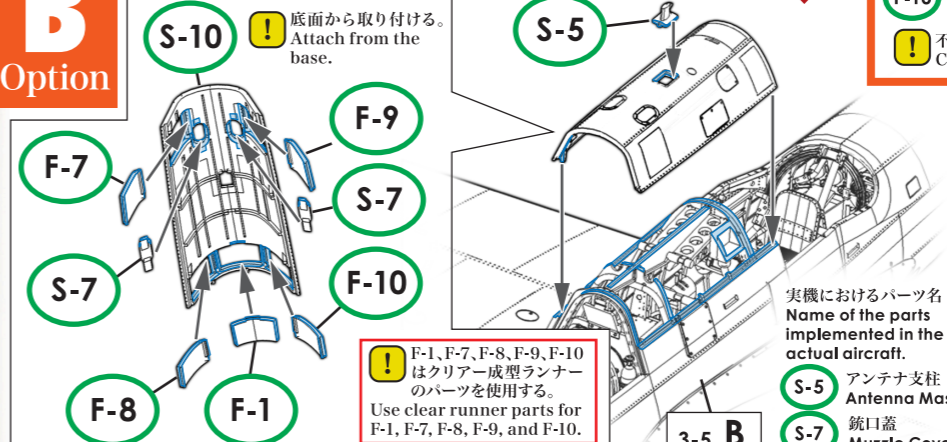

実機におけるパーツ名  
Name of the parts implemented in the actual aircraft.

- F-9 F-7 F-8 F-1 窓ガラス Window Pane
- F-10
- S-10 胴体上部外板 Fuselage Upper Outer Panel
- S-5 アンテナ支柱 Antenna Mast
- S-7 銃口蓋 Muzzle Cover

