

3-1. F イグニッションコード (左側) Spark Plug Cord (Left)

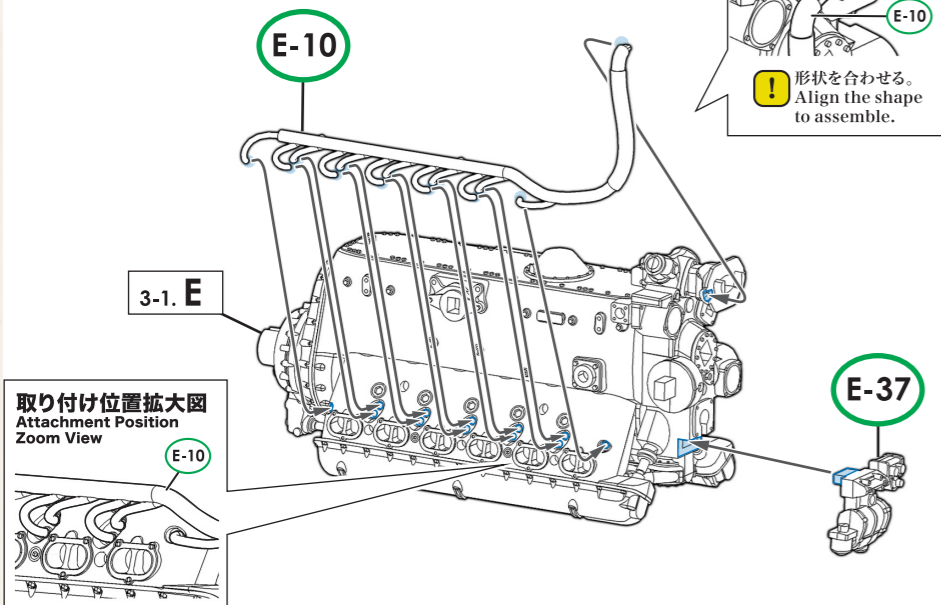

実機におけるパーツ名
Name of the parts implemented
in the actual aircraft.

- E-10 イグニッションコード (左側)
Spark Plug Cord (Left)
- E-37 オイルポンプ
Oil Pump

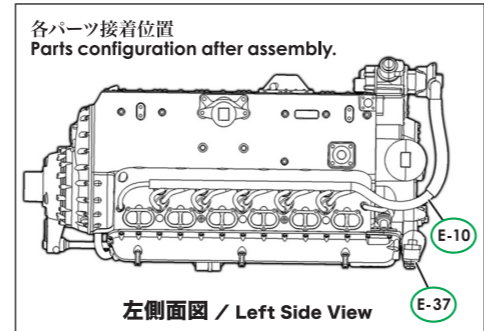

3-1. H 吸気パイプ Air Intake Pipe

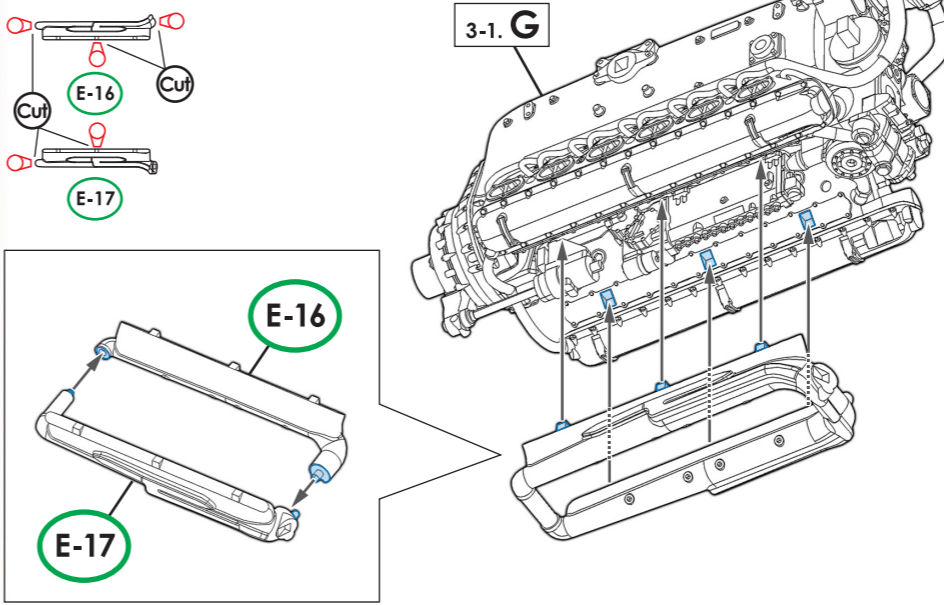

実機におけるパーツ名
Name of the parts implemented
in the actual aircraft.

- E-16 吸気パイプ
Air Intake Pipe
- E-17

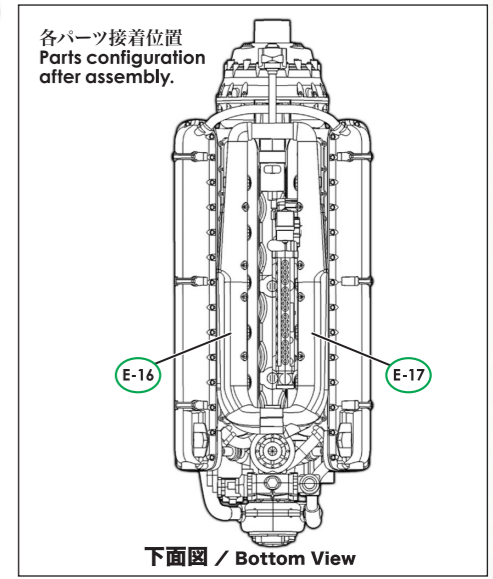

3-1. G イグニッションコード (右側) Spark Plug Cord (Right)

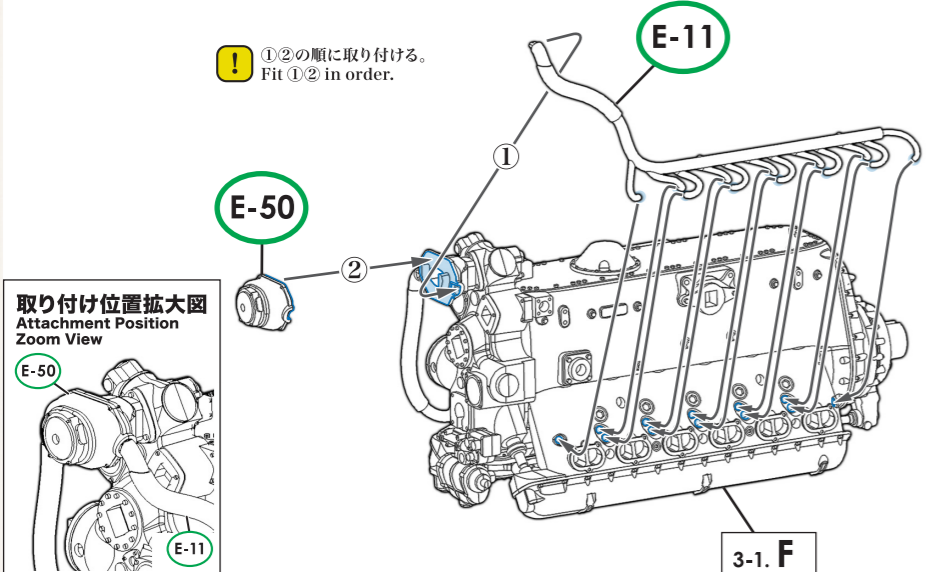

実機におけるパーツ名
Name of the parts implemented
in the actual aircraft.

- E-11 イグニッションコード (右側)
Spark Plug Cord (Right)
- E-50 ツインマグネトー
Twin Magneto

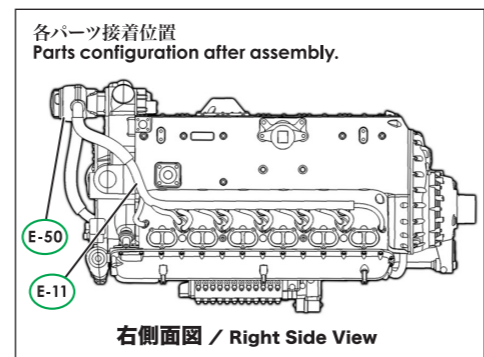

3-1. I 過給器 Supercharger

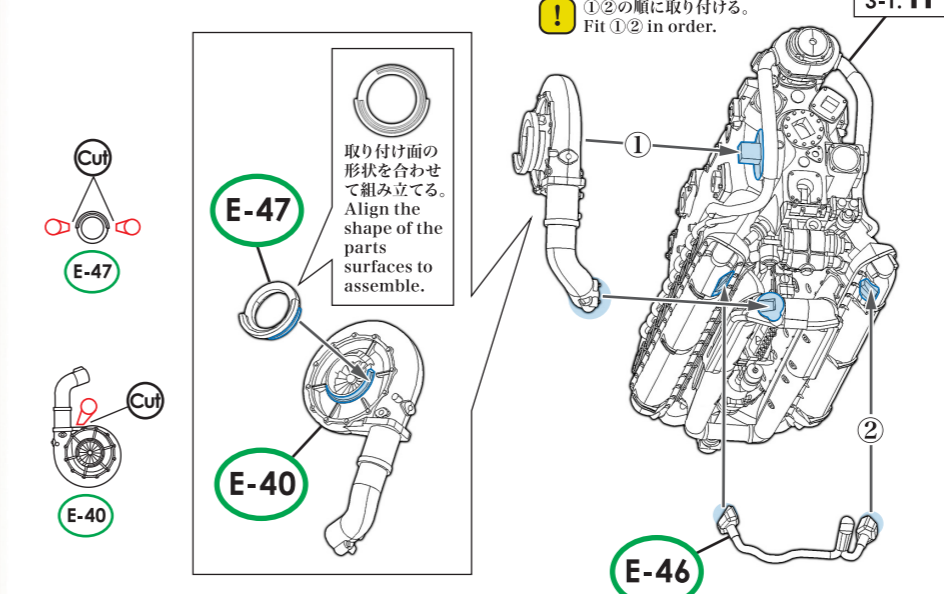

実機におけるパーツ名
Name of the parts implemented in the actual aircraft.

- E-40 過給器
Supercharger
- E-47

