

3-1. K

拡大写真 / Zoom View

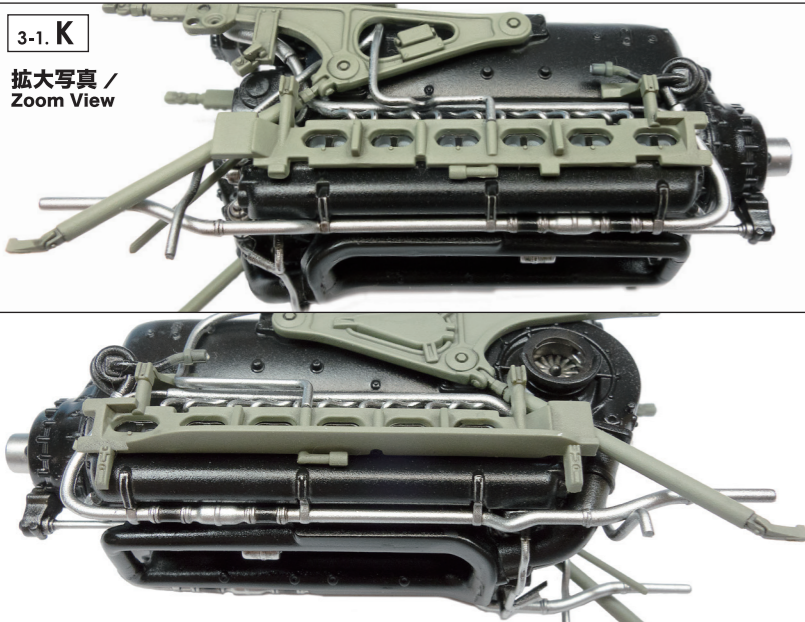

3-1. L

冷却液タンク Cooling Fluid Tanks

準備工作 Preparation

! 赤色部分を切り落とす。 Cut the red parts off.

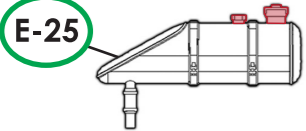

E-24

! 破損注意!! Careful- delicate parts!!

E-25

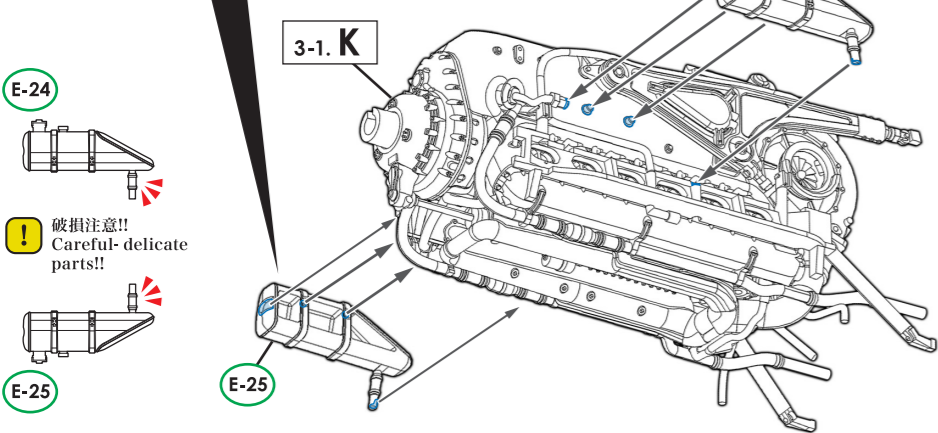

実機におけるパーツ名 Name of the parts implemented in the actual aircraft.

E-24 E-25 冷却液タンク Cooling Fluid Tanks

各パーツ接着位置 Parts configuration after assembly.

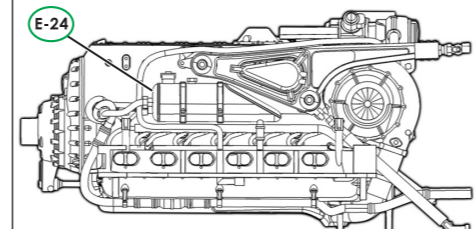

左側面図 / Left Side View

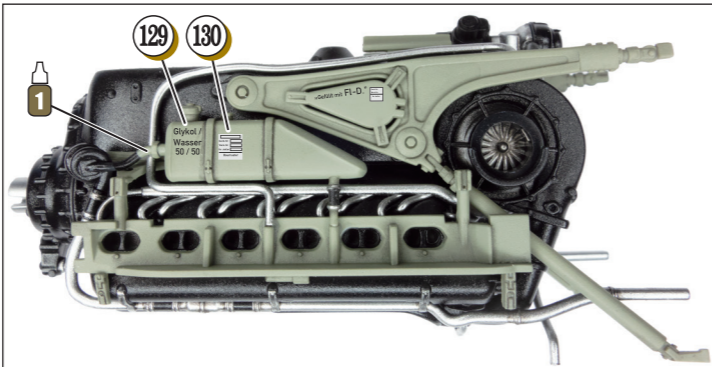
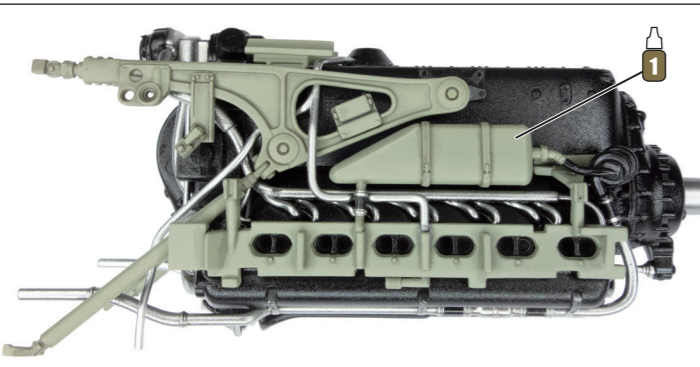

3-1. M オイルタンク Oil Tank

取り付け位置 拡大図 Attachment Position Zoom View

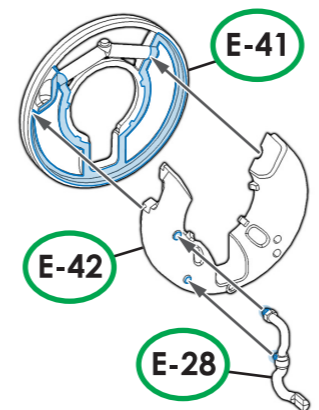

! 前方からスライドさせて取り付ける。 Slide E-6 backward to attach.

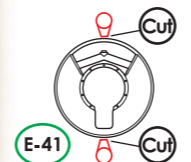
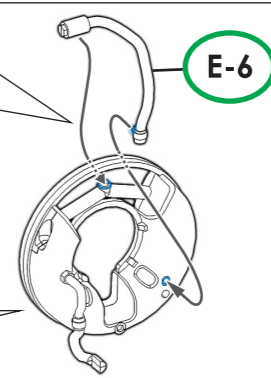

! 図の突起とエンジン本体の形状を合わせて取り付ける。 Attach to the pins and align the engine shape to assemble.

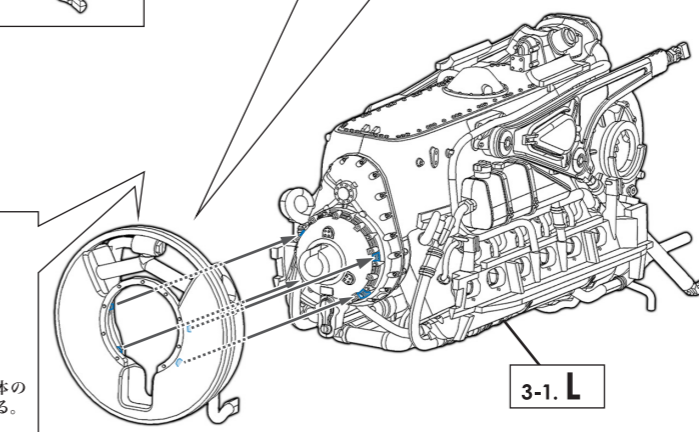

実機におけるパーツ名 Name of the parts implemented in the actual aircraft.

E-41 E-42 オイルタンク Oil Tank

各パーツ接着位置 Parts configuration after assembly.

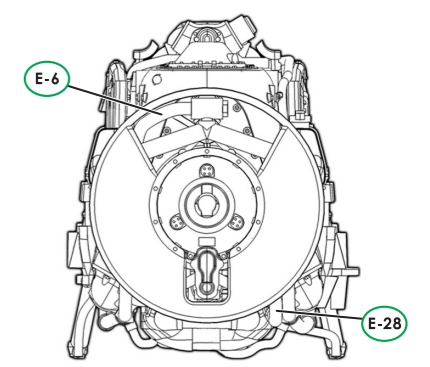

正面図 / Front View

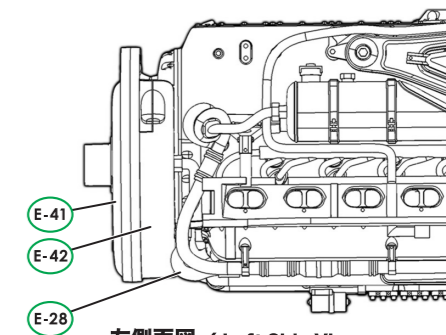

左側面図 / Left Side View

3-1. N 配管類 Pipes

取り付け位置 Attachment Position

