

3-5. C フラップ (右翼) Flap (Right)

! フラップの上げ下げの選択を行い、加工して組み立てる。
Choose the flap "raised" or "lowered" and install the
parts after applied the "Preparation" for each position.

実機におけるパーツ名
Name of the parts implemented in the actual aircraft.

B-3 B-4 フラップ (右翼)
Flap (Right)

各パーツ接着位置 Parts configuration after assembly.

フラップ上げ状態 / Landing Flaps: Raised Position

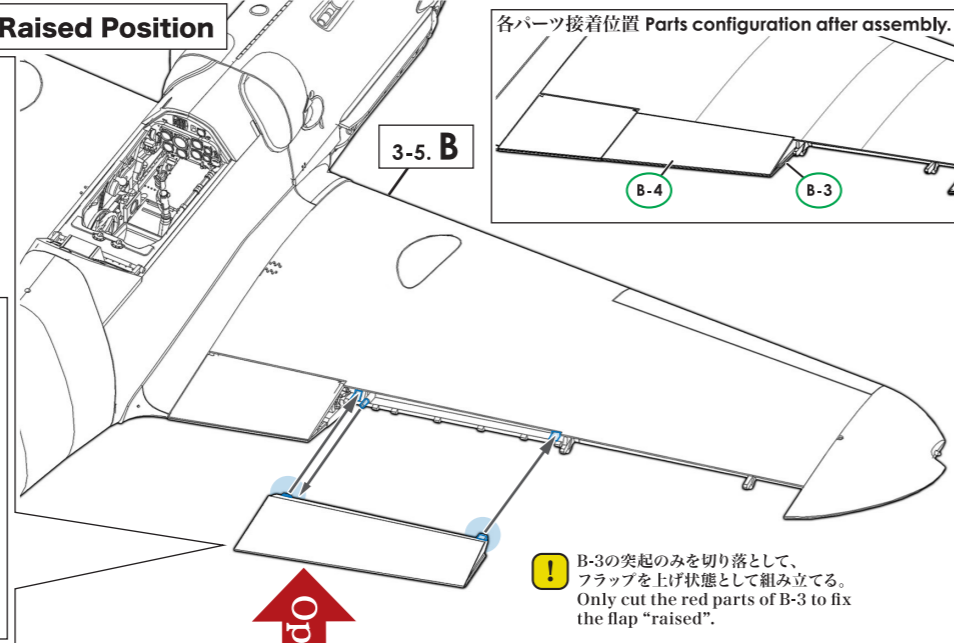
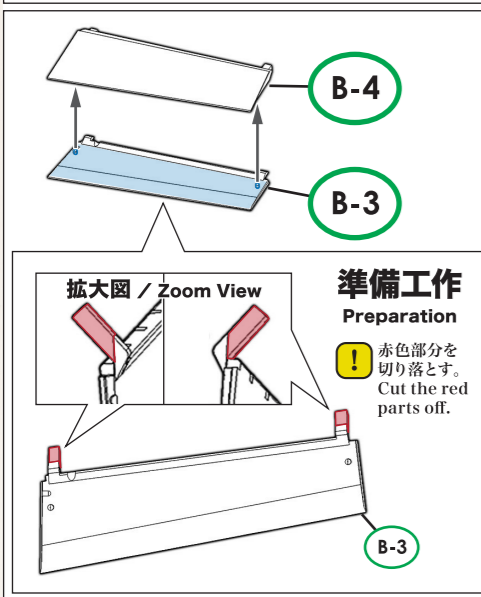

フラップ下げ状態 / Landing Flaps: Lowered Position

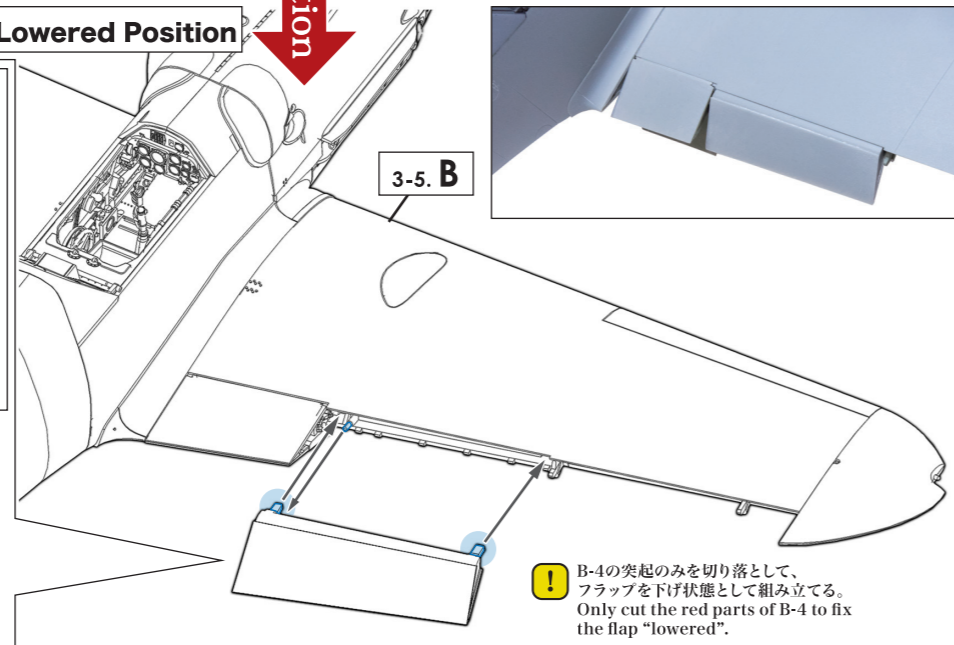
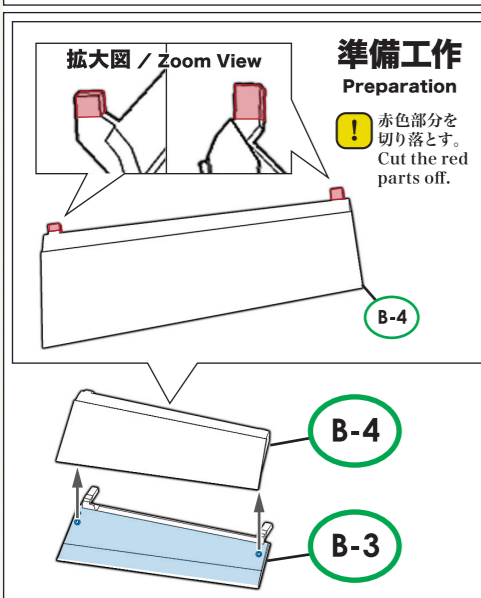

3-5. D エルロン (右翼) Aileron (Right)

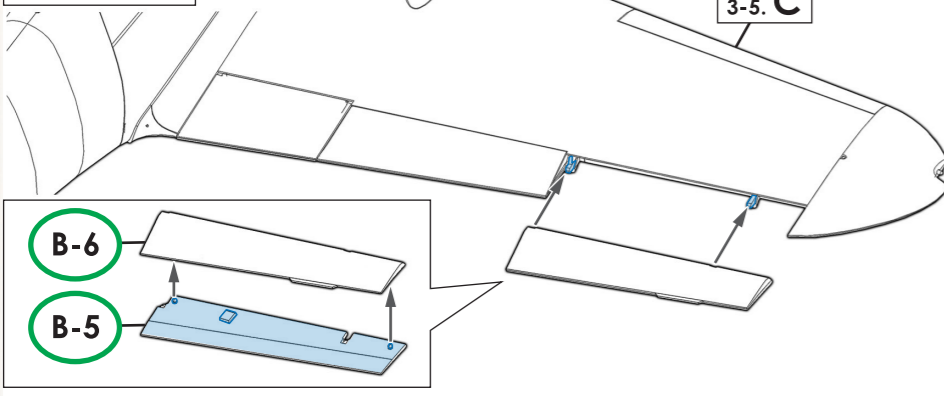

実機におけるパーツ名
Name of the parts implemented in the actual aircraft.

B-5 B-6 エルロン (右翼)
Aileron (Right)

各パーツ接着位置 Parts configuration after assembly.

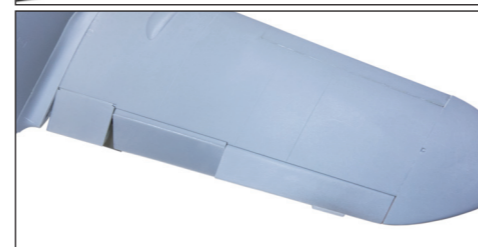

3-5. E フラップ (左翼) Flap (Left)

! フラップの上げ下げの選択を行い、加工して組み立てる。
Choose the flap "raised" or "lowered" and install the
parts after applied the "Preparation" for each position.

実機におけるパーツ名
Name of the parts implemented in the actual aircraft.

B-7 B-8 フラップ (左翼)
Flap (Left)

各パーツ接着位置 Parts configuration after assembly.

フラップ上げ状態 / Landing Flaps: Raised Position

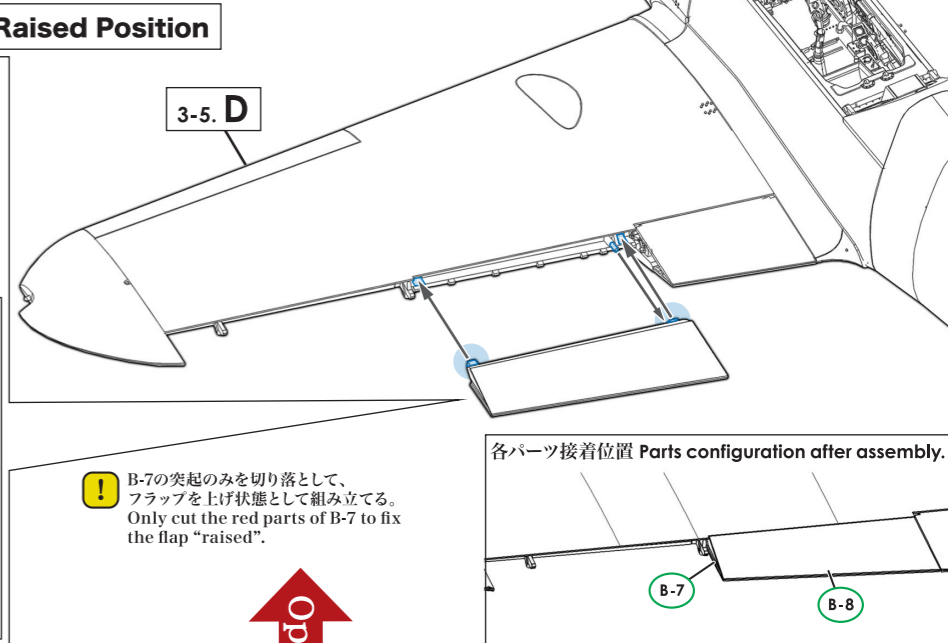
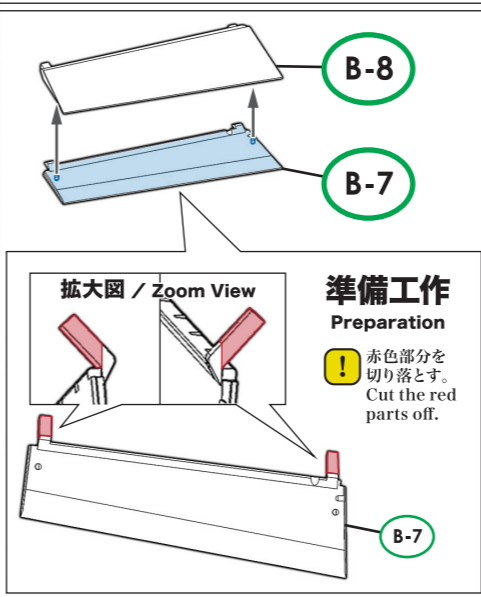

フラップ下げ状態 / Landing Flaps: Lowered Position

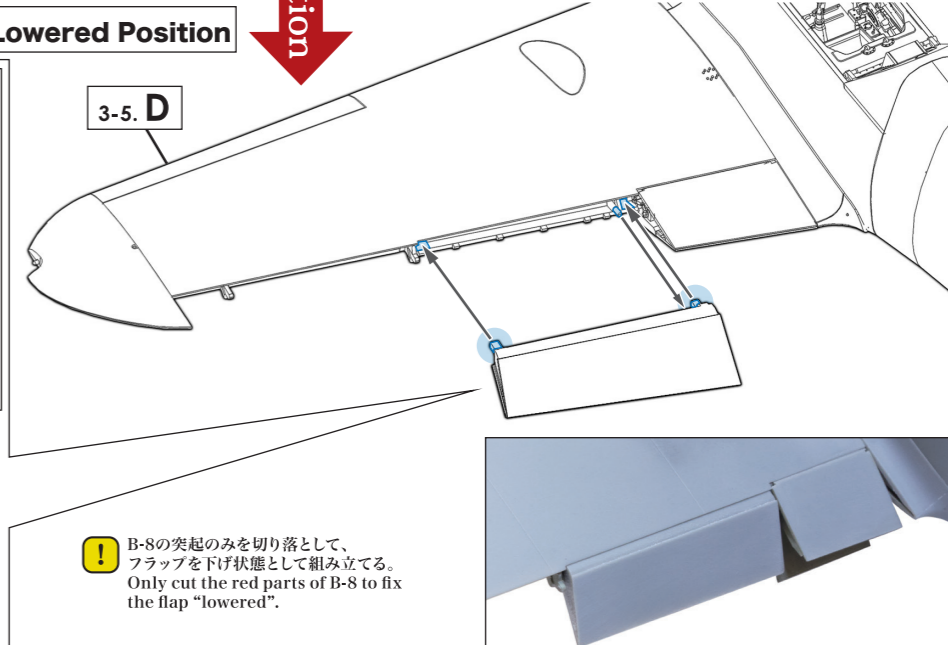
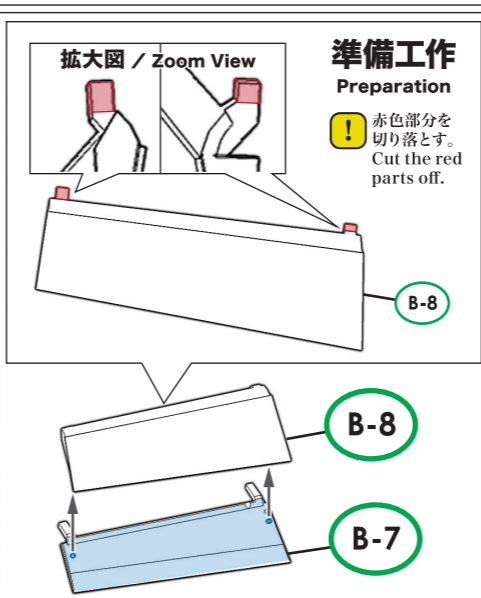

3-5. F エルロン (左翼) Aileron (Left)

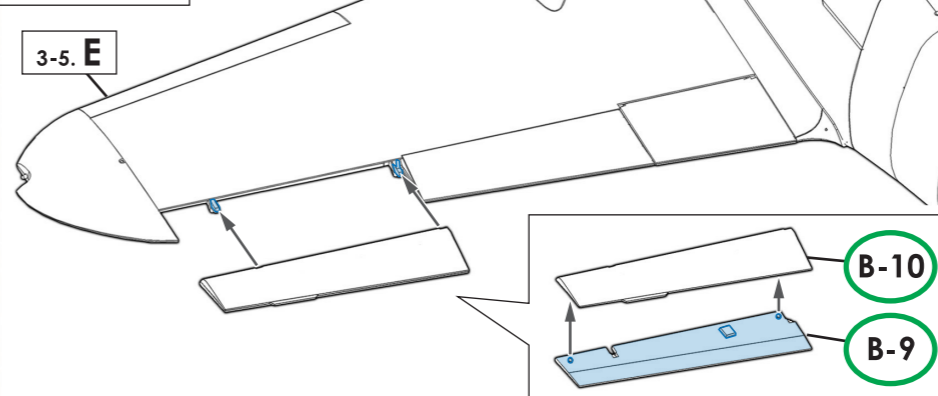

実機におけるパーツ名
Name of the parts implemented in the actual aircraft.

B-9 B-10 エルロン (左翼)
Aileron (Left)

各パーツ接着位置 Parts configuration after assembly.

