

Attention!

- This item is meant for hobbyists 15 years of age or older. Please do not give this item to children under 15.
- This item is intended for use with the Zoukei-mura 1/32 "Ta 152".
- The polyethylene bags that contain the parts and assembly manual present a suffocation risk. Please do not drop the parts or bend them in unintended ways, as they may be damaged.
- In order to properly express the shape of the sculptures, it was unavoidable for some parts to have sharp edges. Please be careful.

This is a resin kit. Please note that these parts cannot be glued with plastic model kit cement. Instant glue should be used instead.

SUPER WING OPTIONS



SWS02-F04

1/32 ZOUKEI-MURA INC. PRESENTS
1/32 SUPER WING SERIES, No.02

Ta 152 H-1

Forward Facing Pilot Figure

1/32
Ta 152 H-1

Exclusive
Pilot
Figure

造形村
ZOUKEI-MURA INC.



Photo shows assembled and unpainted model kit. Cockpit is not included.

©ZOUKEI-MURA INC. All Rights reserved.

造形村
ZOUKEI-MURA INC.
<https://www.zoukeimura.co.jp/>

〒105-8501 東京都港区新橋3-15-1
Zoukei-Mura Inc.
■ Distributor: VOLKS, Inc.
60 Goshomachi Nakamachi, Shichi-jo,
Shimogyo-ku, Kyoto Japan 600-8862

Forward Facing Pilot Figure



4 518992 503677

1/32 "Ta 152" Assembly Instructions

These parts will be inserted when assembling the 1/32 "Ta 152" kit. Please refer to the instruction manual of the "Ta 152 H-1".

◆ Pilot Assembly

Pay attention to the "Important Points for Assembly" when you assemble the resin parts of this set.

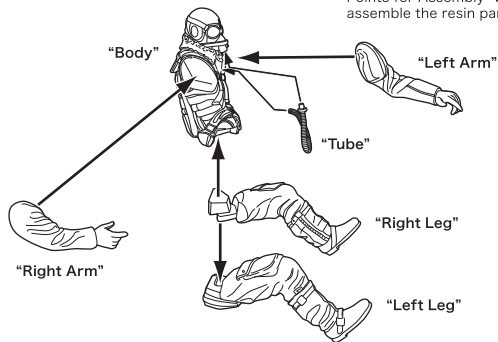

◆ How to Insert the Pilot in the Aircraft

1/32 Ta 152 H-1
Instruction Manual P. 7

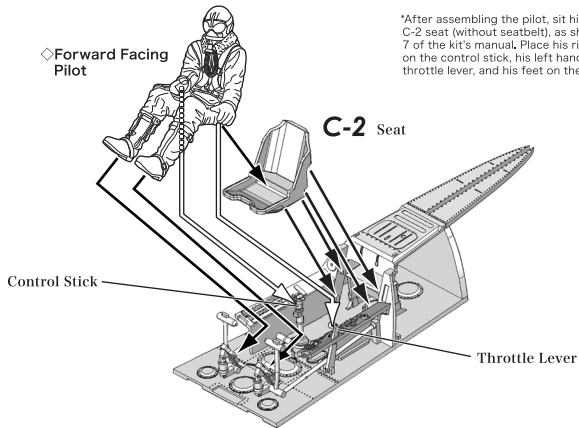

*After assembling the pilot, sit him on the C-2 seat (without seatbelt), as shown on p. 7 of the kit's manual. Place his right hand on the control stick, his left hand on the throttle lever, and his feet on the pedals.

◆◆ Important Points for Assembly ◆◆

- Please carefully read the assembly manual prior to opening and make sure that everything is included.
- To use this item, tools such as **■Nippers**, **●craft knife**, **●files**, **●sanding papers**, **●instant glue**, etc., are required, so please prepare them.
- Please prepare the parts first. You can remove seam lines and gate marks with tools such as nippers, a craft knife and files. Urethane resin is softer than the plastic material used for the kit, so be careful to avoid carving too much. Air bubbles can be filled with putty (epoxy, plastic, etc.) or similar, then finished with sanding paper. In the case that mold details are lost, you can recover them with tools such as spatulas.
- During assembly, adjust the orientation of each part while checking the balance and pose of the entire kit.
- Instant glue should be used for these parts. Please note that they cannot be glued with plastic model kit cement.
- We recommend using brass wire (sold separately) to reinforce the areas where the parts are glued together. Use a pin vise and drill bit to open a hole on both sides of each gluing surface, then insert the ends of a brass wire into the holes to connect the sides. This will greatly increase the strength of each joint. (Using the wires without glue to temporarily build a figure is called dry fitting. We recommend doing so in order to check each figure's balance.)
- Base preparation is required before painting. Please thoroughly finish the base with a coat of surfacer spray (otherwise, the paint will chip off as time passes).
- The recommended brand for painting your kit is the latest line of paint from Vallejo Color, due to its non-toxicity and environmental friendliness. While referring to resources on historical Luftwaffe aircrafts, you may paint the model with the coloring of your choice.

※When it comes time to use tools and paints, please carefully follow the individual instructions respective to each tool for your safety.

Chart of Included Parts

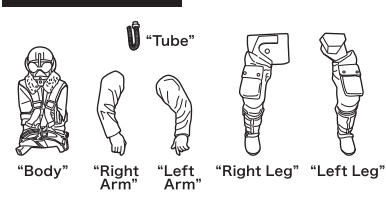

We take the utmost of care when overseeing manufacturing, but if your kit is among the very small percentage that contains a defective part, please contact customer service within two weeks of your purchase with your full name and order number.

Purchasers from VOLKS Japan
International Web Site : Please
contact imos@volks.co.jp
Purchasers from VOLKS USA : Please
contact service@volksusa.com